



Installation Manual V4.3

# SBW Series Wi-Fi Clock



The Sapling Company, Inc.  
670 Louis Drive  
Warminster, PA 18974  
USA

P. (+1) 215.322.6063  
F. (+1) 215.322.8498  
[www.sapling-inc.com](http://www.sapling-inc.com)

# SBW Series Wi-Fi Clocks - Table of Contents

*Interactive Hyperlinked PDF – Click on the topic and the document will go to the relevant page. Clicking on the logo will take you back to the table of contents.*

Table of Contents	2	Web Interface	
Important Safety Instructions	3	- Log In	51
Identify Your Clock	4 - 5	- Home Page	51
System/Network Requirements	6	- Network Settings	52 - 53
Synchronization System Setup	7 - 8	- Enterprise Encryption Settings	54
Configure Multiple Clocks with wifiDirectLoader	9 - 10	- General Settings	55
Before Installation		- Time Settings	56
- Network Monitoring Software	11	- Daylight Saving Time	57
- DHCP	12	- Servers	58
- Static IP	13	- Display Settings	59
- Clock Setup - GMT/UTC Offset	14	- Brightness Schedules	60
- Clock Setup - Network Servers	15 - 17	- Elapsed Timer	61 □
Preparing for the Installation	18	- Login Settings	62
Wall Mounted Clock Mechanical Installation	19 - 23	- Diagnostics	63
Dual-Faced / Flag Mounted Digital Clocks Overview	24	- Troubleshooting	64
Dual-Faced / Flag Mounted Clock Mechanical Installation	25 - 32	- Input and Relay Settings	65 ■
Uniform Stage Installation	33 - 35	- Inputs	66 - 67 ■
Re-enabling Direct Mode	36	- Outputs	68 - 69 ■
Temperature Sensor Installation	37 □	- End Countdown	70 ■
Buzzer Installation	38 ■	- Software Update	71
User Input Installation	39 ■	Manual Controls	72
Network Monitor Software		Frequently Asked Questions	73
- Main Screen	40 - 42	Troubleshooting	74 - 75
- Task Bar Options	43 - 47	Warranty	76
- Quick Access Menu	48 - 49	FCC Statement	77
- Error Messages	50		

Manuals may change without prior notice

<p>□ Available with 3200 and 3300 models</p> <p>■ Available with 3300 model only</p>
--

## Important Safety Instructions

### VERY IMPORTANT:

CONFIGURE YOUR CLOCK BEFORE MOUNTING IT TO A WALL OR HOUSING. REFER TO THE SYNCHRONIZATION SYSTEM SETUP SECTION OF THIS MANUAL FOR INSTRUCTIONS.

All network equipment must be powered and configured before you install the clock. If the network equipment is not properly installed and powered, and if the clocks have not been configured to communicate with the network equipment, the secondary clocks will not synchronize.

### DANGER



#### SHOCK HAZARD

- Keep the electricity to this device turned OFF until the clock installation is complete.
- Do not expose the clock circuits to water, or install the clock in a location where it may be exposed to water.

### NOTICE

- Do not install the clock outdoors. Damage to the clock if placed outdoors voids the warranty.
- Do not hang objects from the clock or clock mounting parts. The clocks are not designed to support the weight of other objects.
- The clock face and housing may be cleaned with a damp cloth or disinfectant. Test other cleaning products on a small part of the clock housing before attempting to use on the rest of the clock. Avoid bleach and chemicals known to dissolve plastics.

### WARNING



#### FIRE HAZARD

- Always follow your national and regional electrical codes or ordinances.
- The AC power circuit for the clock must be attached to a circuit breaker that can be reset by the user.



#### PHYSICAL INJURY HAZARD

- If you are standing on an object while installing your clock, make sure that the object can support your weight, and will not sway or move as you stand on it.
- Take precautions to avoid injury by potential safety hazards near the point of installation including (but not limited to) heavy machinery, sharp objects, hot surfaces, or exposed cables carrying an electric current.
- Follow all mounting instructions exactly as stated in this manual. Failure to do so may result in the device falling off the point of installation.
- Packaging materials and mounting items include plastic bags and small pieces, which pose a suffocation hazard to young children.

---

## Identify Your Clock

---

**A label containing the part number of your clock is attached to the clock packaging**

If your part number begins with SBW-31, it is a 3100 Series clock

If your part number begins with SBW-32, it is a 3200 Series clock

If your part number begins with SBW-33 it is a 3300 Series clock

## Identify Your Clock

The digital clocks are offered at either 3100, 3200, or 3300 Series number. The higher the series number indicates that the clock has higher feature set and capabilities.

### 3100 Series clock electric board layout:

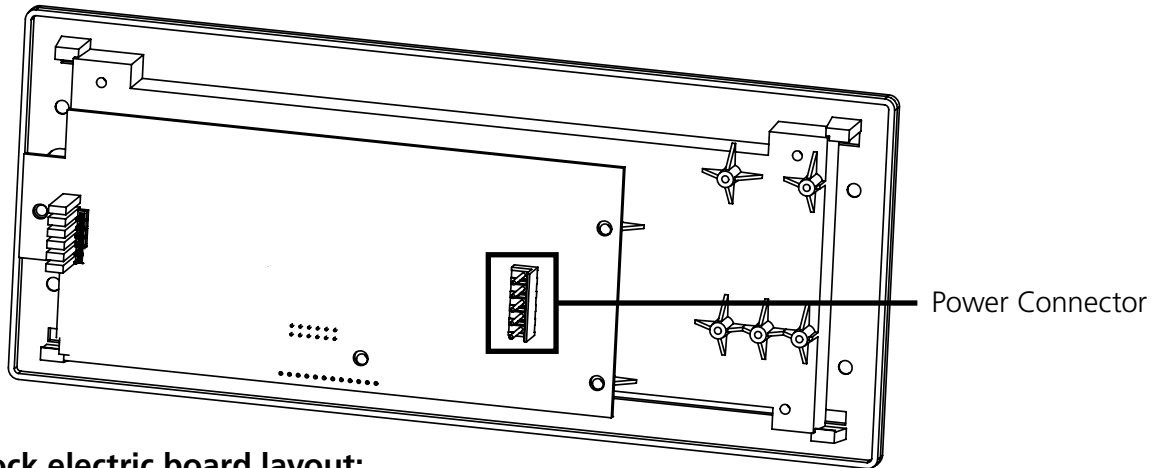

### 3200 Series clock electric board layout:

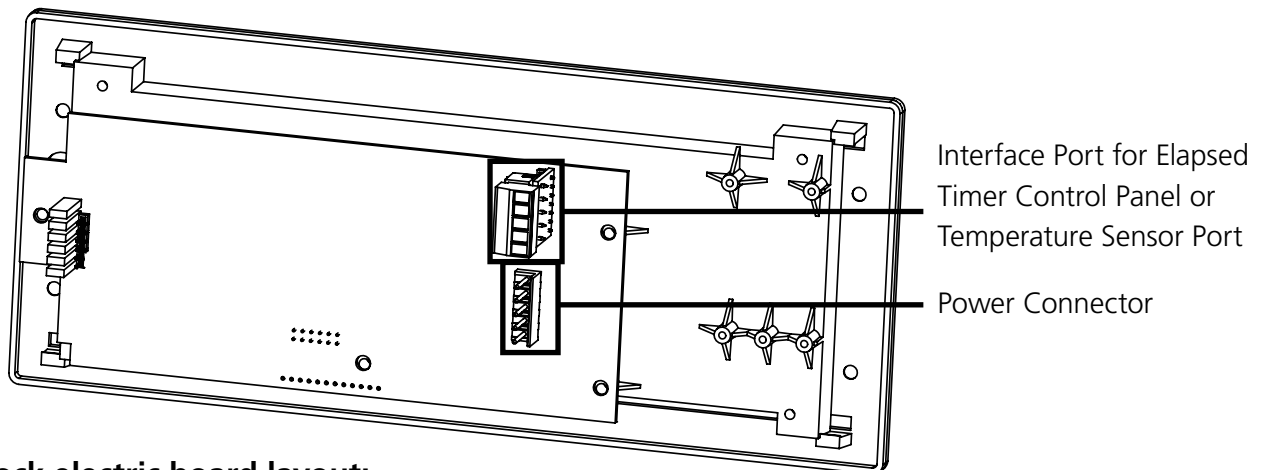

### 3300 Series clock electric board layout:

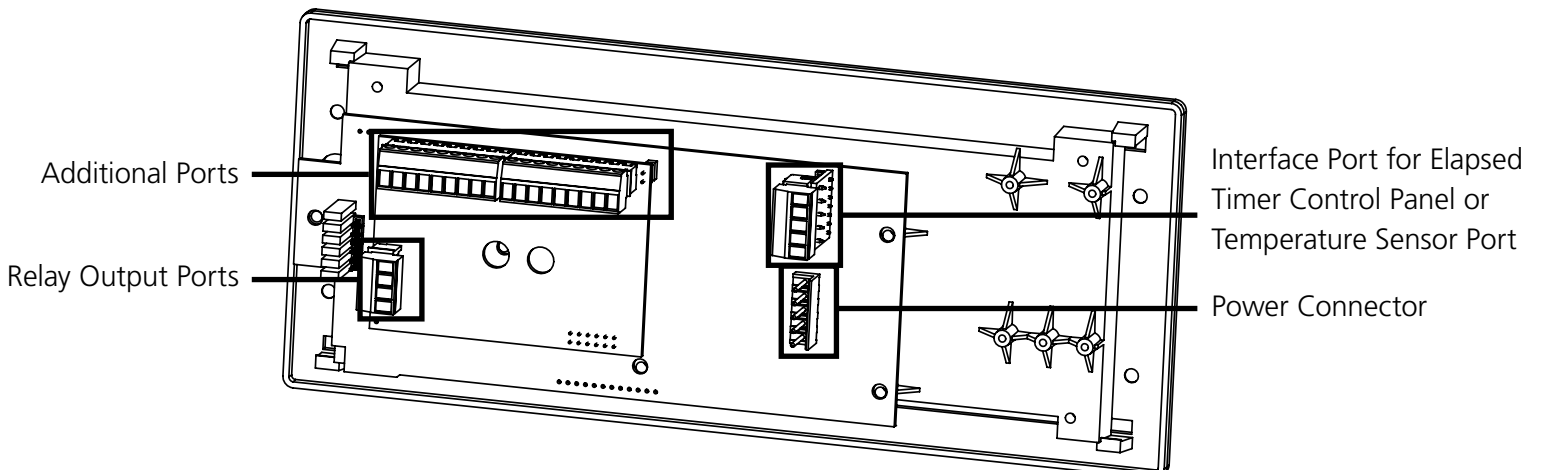

## System/Network Requirements

To be able to set up an IP-based synchronized clock network, you will need the following items:

- This manual
- A Wireless Local Area Network (WLAN) that has access to at least one of the following:
  - An in-house NTP server
  - The Internet
- A local firewall that is open on Ports 80 (TCP), 123 (UDP), and 1777 (UDP)
  - Port 123 is to allow the clock to get time data from NTP Time Server(s)
  - Port 80 is to allow access to the clock's built-in web interface (HTTP)
  - Port 1777 is to allow the NET-MON-SOFT to identify our clocks that are on the network and present them on the network monitoring software
- At least one laptop or desktop computer with access to the following:
  - The same LAN as the clocks
  - The same subnet as the clocks
  - A web browser such as Internet Explorer, Microsoft Edge, or Mozilla Firefox
  - An internal or external Wi-Fi network card
- A wireless router or wireless access point that broadcasts using an 802.11 b/g/n protocol
  - Depending on the size of the network, you may need to install additional Wireless Access Points
- A copy of the Network Monitor program
- Security access to all of the above items
- We also recommend keeping a record of the clock serial numbers, locations, and IP addresses by creating a table like the one shown below:

LINE #	SERIAL #	CLOCK NAME / LOCATION	IP ADDRESS	MAC ADDRESS
1				
2				
3				
4				
5				
6				
7				
8				
9				
10				

## Synchronization System Setup

### Positioning the Wireless Router or Wireless Access Point (WAP):

The main router or WAP should be installed in a central location. Depending on the transmission protocol of your router, the clocks must be located within the following ranges:

Wi-Fi Protocol	Range (Feet)	Range (Meters)
802.11 b	115 feet	35 meters
802.11 g	125 feet	38 meters
802.11 n	230 feet	70 meters

Check with the access point or router manufacturer, as some transmitters offer boosted ranges.

\*NOTE: This clock is not compatible with 802.11a or 802.11ac protocols. Many AC-compatible routers and access points are backwards compatible with 802.11n. Check your router settings for more information.

Be aware of walls or other obstructions made of thick concrete or sheet metal, as these may block the signal entirely.

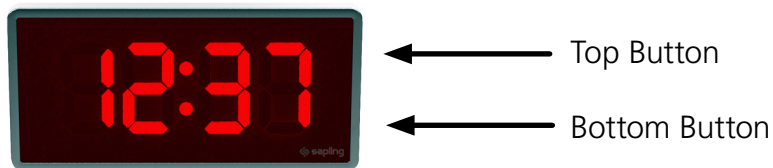

### Logging into the SBW for the first time:

1. Power the clock. Press and release the Top Button on the front panel twice.
2. On a Wi-Fi enabled computer, check the available Wireless Networks. Refresh the available networks until a network named Wifi-DIGITAL-#### appears (where #### is the serial number of the clock). This may take up to 30 seconds. Once it appears, connect to this network.
3. Open a web browser and enter the following web address into the URL field:  
**192.168.240.1/login.html**
4. On the login page, use the password **6063** and click on **Submit** to log into the clock.

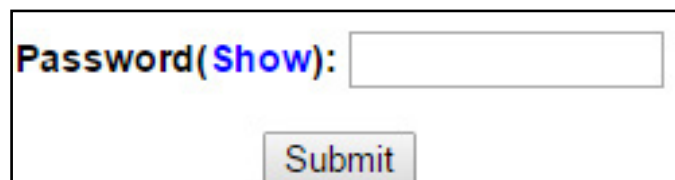

5. Click on the **Network Settings** button.

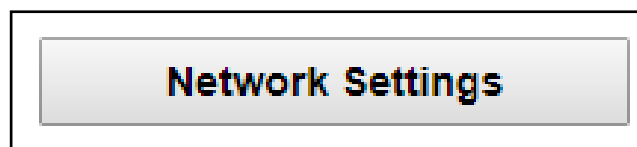

## Synchronization System Setup

### NETWORK SETTINGS

	Clock Name:	Room 302
	Serial Number:	1109
	MAC Address:	60:36:96:0a:00:6d
	Select Network:	Series 1 ▼
6	Network:	Series 1
7	Network Password (Show):	
	DHCP Auto On:	On ▼
8	IP Address:	192.168.4.4
	Subnet Mask:	255.255.255.0
	Gateway Address:	192.168.4.1
9	Auto DNS:	On ▼
	DNS Address:	192.168.0.31
	Broadcast to Monitors:	On ▼
	Send Specific Monitor IP:	Off ▼
	Monitor IP Address:	0.0.0.0

10   11

6. In the **Network** field, enter the SSID of your preferred Wi-Fi network. This is the name that appears if you try to connect to that Wi-Fi network on any other computer, tablet, or smart phone. If you do not remember the name of your network, check to see if it has appeared in the **Select Network** list. A network that does not broadcast its SSID will not appear in this list. **SSIDs must use only English letters, numbers, and spaces. No symbols.**

7. In the **Network Password** field, enter the password of your preferred Wi-Fi network. Network passwords must be 32 characters or fewer, and are case-sensitive.

8. If you wish to set a static IP address, change DHCP Auto On from ON to OFF, then enter information for the Static IP address, Subnet Mask, and Gateway Address. To acquire this information, contact your network administrator.

9. If you wish to set a DNS server other than the one provided through DHCP, change DHCP Auto On from ON to OFF, change Auto DNS from ON to OFF, then enter an IP address for a new DNS server in the DNS Address field.

10. If your network does not use Enterprise Encryption, skip this step. If your network uses WPA2-Enterprise Encryption, click on the **Enterprise Settings** button and fill in the fields appropriate to your network. To acquire this information, contact your network administrator. When finished, press **Submit** to return to this page.

11. Press the **Submit** button, followed by the **Log Out** button.

12. The clock should connect to the new Wi-Fi network. Confirm by accessing the clock with the Network Monitor (If clock DHCP is on and the computer is on the same subnet as the Access Point) or the new static IP address (if clock DHCP is off). If the clock is still not accessible, refer to the section of this manual labeled "Troubleshooting"



## Configuring Multiple Clocks with wifiDirectLoader

wifiDirectLoader.exe is a piece of software that lets a user rapidly duplicate existing clock settings to other clocks of the same type (analog or digital). This is useful for large clock systems, where a user may not have the time to configure many clocks individually.

**NOTICE: Starting wifiDirectLoader.exe will take your computer off of its current Wi-Fi network. If you need to access your network while simultaneously running this software, connect the computer to the network using a LAN cable.**

This software can also be downloaded from our website: <https://sapling-inc.com/software/>

### Obtaining the configuration file:

1) **DO NOT Start wifiDirectLoader.exe.** First, set up one clock using the steps described in the Synchronization Setup section of this manual.

2) Once you have completed all the steps, exit the clock.

3) Start wifiDirectLoader.exe by double-clicking on it.. Enter the value "6063" in the password field.

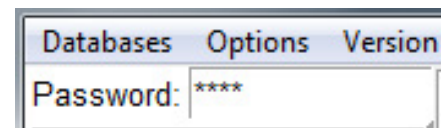

4) Power the clock. **Press and release the Top Button on the front panel twice.**



← Top Button  
← Bottom Button

5) In the wifiDirectLoader.exe window, an entry should appear for the clock.

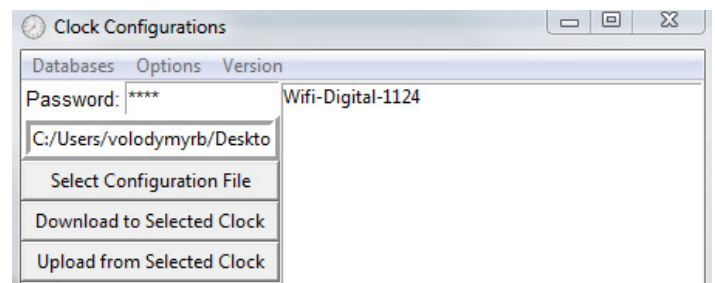

6) Click on the entry name for the clock, then press on the "Upload from Selected Clock" button.

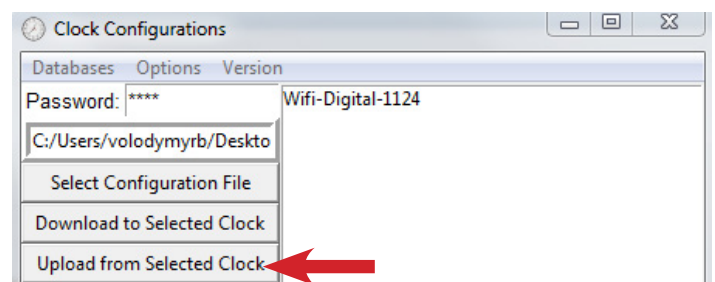

7) Save the configuration file to an easily-accessible location, like your Documents or Desktop folder.

## Configuring Multiple Clocks with wifiDirectLoader

### Before Applying the configuration file:

The fastest way to perform this process is to collect all of the Wi-Fi clocks in a single room and run this program. Alternatively, you can take a Wi-Fi-capable laptop that runs the wifiDirectLoader software while you go in proximity of each clock.

### Applying the configuration file:

1) Press on the "Select Configuration File" button. Use the window to select the configuration file that you downloaded from the first clock. If you cannot see the file, confirm that the Types of File field is set to Digital WiFi (\*.dwifi).

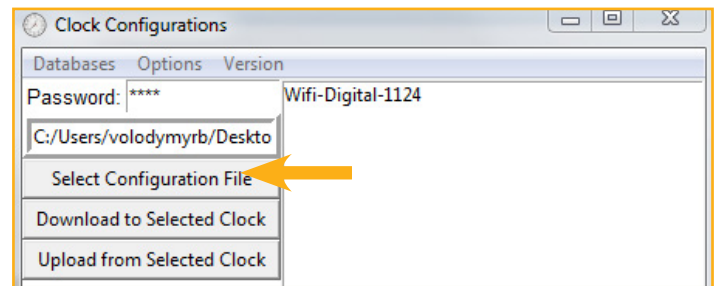

2) Under the Options menu, select "Auto Run."

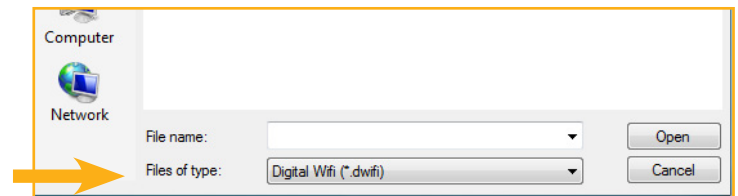
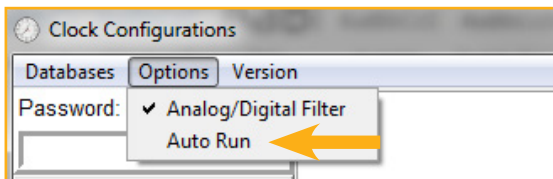

3) Power additional clocks and place them into direct mode using Step 4 from the previous page.

4) wifiDirectLoader.exe will automatically program every clock that appears. Clocks can be identified by their Serial Number, which will appear as part of the name of each clock that appears in the field to the right of the buttons.

5) Once each clock is programmed, the clock may be powered down, then mounted on the wall using the instructions in the following sections.

6) Once all clocks are programmed, exit out of wifiDirectLoader. You will be unable to access any other networks if wifiDirectLoader is still running.

---

## Before Installation - Network Monitoring Software

---

The clock is provided with a Network Monitoring Software, allowing the user to view, program, and monitor the clocks (displays). The Network Monitoring Software will be used once the clock(s) has been powered and connected to the network. Therefore, at this stage, the software should be ready and available, and will require downloading the software on a computer.

In addition to the CD, the Network Monitoring Software is also available to be downloaded from our website as per the below link. Please also note that the Network Monitoring Software is available in two different versions: One version is meant for the hard-wired network clocks, while the second version is meant for the Wi-Fi network clocks. Make sure that you download the correct software version depending on the type of clock you have.

<https://sapling-inc.com/software/>

### Instructions for downloading and installing the Network Monitoring Software:

1. Create a folder on your computer called *Network Monitor*
2. If you have the Network Monitor on a CD:
  - a. Load the CD into your computer's CD Drive
  - b. Open the file on the CD and select the file ending in extension ".exe"
  - c. Copy the file to your Network Monitor folder.
3. If you downloaded the Network Monitor from our website: <https://sapling-inc.com/software/>
  - a. Locate the Network Monitor file in your computer's Downloads folder.
  - b. Select the file and copy all of its contents to your Network Monitor folder.
4. If you received the Network Monitor as an email attachment, refer to your email provider's instructions for downloading email attachments.
5. In order to use the Network Monitoring Software, port 1777 must be open in the facility's firewall.
6. If your computer has a security software in use, please make sure that it is not blocking the network monitoring software (if it is, you need to allow it to run by having it "whitelisted" on your computer).
7. Once the software is running on your computer, you can proceed with the next steps of the installation instructions. At this stage, no clocks (displays) will appear in the network monitoring software until additional steps are taken, as described later on in this manual.

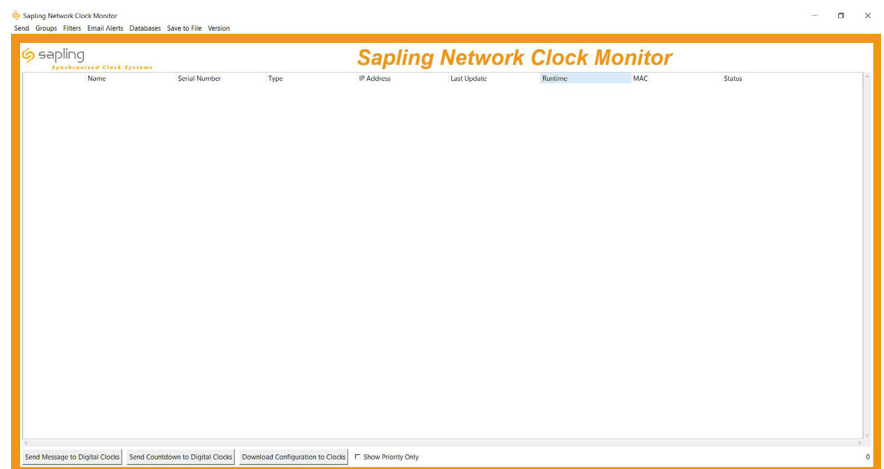

## Before Installation - DHCP

The SBW clock can be set to DHCP or Static IP address.

The clock is shipped in DHCP mode as default. This means that once the clock is connected to the network it is assigned the next available IP address by a DHCP server. It is user changeable, meaning that the clock can be set with a static IP address and that these settings can be changed in the clock built-in web interface (as explained in this manual).

If you wish to be able to access the web interface from a computer, Port 80 must be open.

If you wish to access your clock using a known, unchanging Static IP address, see the next page.

If a user wishes to access the web interface while the clock is in DHCP mode, then there are two ways to find the IP address. The first is to press and hold both buttons on the front of the clock simultaneously, and release them after two seconds. This will cause the IP address to appear on the clock display. The second method is to use the Network Monitoring Software in order to find its IP address. You can also double click on the clock line in the monitoring software to access its built-in web interface.

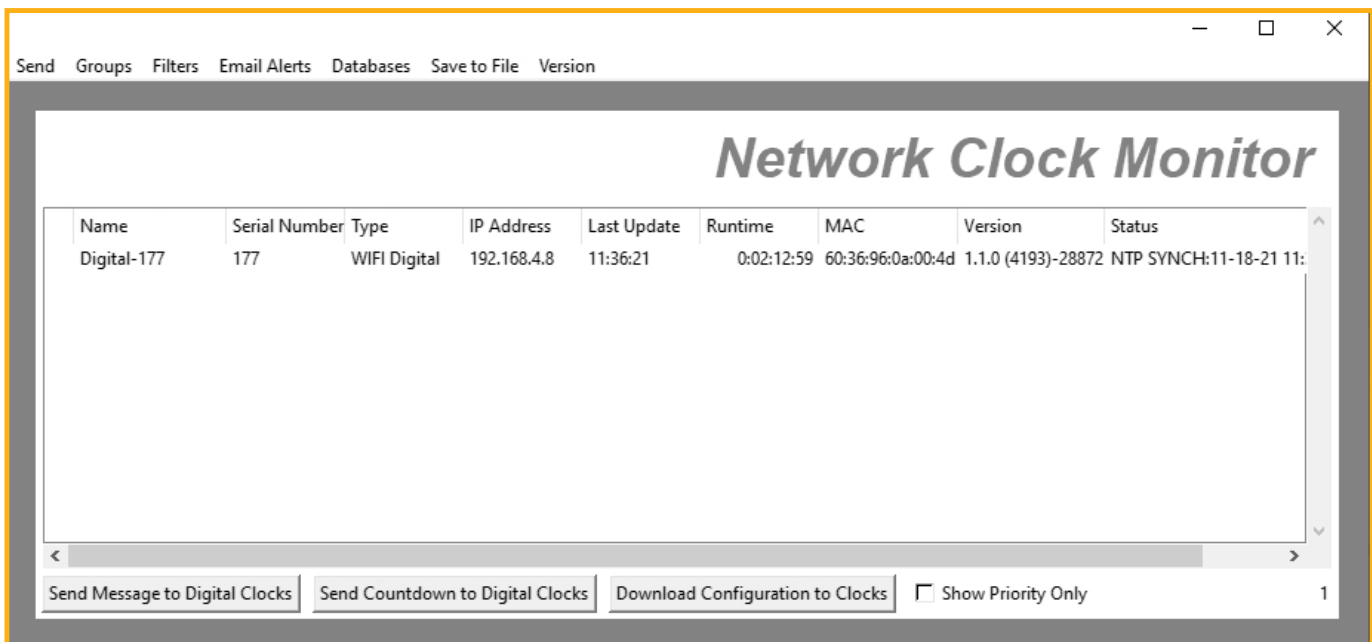

## Before Installation - Static IP

The SBW clock can be set to DHCP or Static IP address.

The clock is shipped in DHCP mode as default. This means that once the clock is connected to the network it is assigned the next available IP address by a DHCP server. It is user changeable, meaning that the clock can be set with a static IP address and changing these settings in the clock built-in web interface (as explained in this manual).

For setting your Wi-Fi clock to a static IP address, please follow these steps:

1. After connecting to the designated Wi-Fi network, access the clock using the designated IP address provided by the DHCP server.
2. To find the clock's dynamic IP address, press the two buttons on the front of the clock and write down the IP address that displays. Alternatively, find the clock serial number provided on the label on the back of the clock, then using the Network Monitoring Software, find this serial number and verify its IP address. The IP address will be listed next to it, as shown in the image below:

Name	Serial Number	Type	IP Address	Last Update	Runtime	MAC	Version	Status
Digital-177	177	WIFI Digital	192.168.4.8	11:36:21	0:02:12:59	60:36:96:0a:00:4d	1.1.0 (4193)-28872	NTP SYNCH:11-18-21 11:

3. Go onto a web browser on a computer that is connected to the same LAN (Local Area Network) as the clock and type the IP address of the clock into the address bar.
4. This should bring you to the web interface of the clock and you will be prompted to log in. The Password is **6063**.
5. Once logged in, select the "Network Settings" tab of the clock's built-in software.
6. In "Network Settings," note the DHCP option. Toggle DHCP from "ON" to "OFF." This will make the current IP address of the clock static.
7. Enter the following parameters provided by your network administrator: Gateway IP Address, Subnet Mask, DNS Router, and the designated Static IP Address of the clock. After entering these settings, click on the "submit" button.
8. After making these network configuration changes, power cycle the clock, wait 10 seconds, and power it again.
9. In order to confirm that the designated static IP address has been properly programmed, press the two buttons on the front display of the clock, which will display the current IP address.

### NETWORK SETTINGS

Image A

Clock Name:	Digital-113
Serial Number:	113
MAC Address:	60:36:96:0a:00:0d
Select Network:	WIFIPROD ▼
Network:	WIFIPROD
Network Password (Show):	
DHCP Auto On:	On ▼
IP Address:	192.168.4.6
Subnet Mask:	255.255.255.0
Gateway Address:	192.168.4.1
Auto DNS:	On ▼
DNS Address:	192.168.0.31
Broadcast to Monitors:	On ▼
Send Specific Monitor IP:	Off ▼
Monitor IP Address:	0.0.0.0

Enterprise Settings Submit

Web Server: V.1.2.0

## Before Installation - Clock Setup - GMT/UTC Offset

1) Double click on the serial number for the clock being installed. This should take you to the web interface for that clock. Use the password **6063** to enter.



The screenshot shows the 'Network Clock Monitor' web interface. At the top, there is a navigation menu with options: Send, Groups, Filters, Email Alerts, Databases, Save to File, and Version. Below the menu is a table with the following columns: Name, Serial Number, Type, IP Address, Last Update, Runtime, MAC, Version, and Status. The table contains one entry: Digital-177, 177, WIFI Digital, 192.168.4.8, 11:36:21, 0:02:12:59, 60:36:96:0a:00:4d, 1.1.0 (4193)-28872, and NTP SYNCH:11-18-21 11:36:21. The 'Serial Number' column is highlighted with an orange box, and an arrow points from it to a 'WIFI CONFIG' form. The form has a title 'WIFI CONFIG', a label 'Password(Show):' followed by an input field, and a 'Submit' button. At the bottom of the form, it says 'Web Server: V.1.2.0'. Below the table, there are two buttons: 'Send Message to Digital Clocks' and 'Send Countdown to'.

2) Select the "Time Settings" tab and then select the GMT/UTC offset for your time zone (for example, New York is -5).

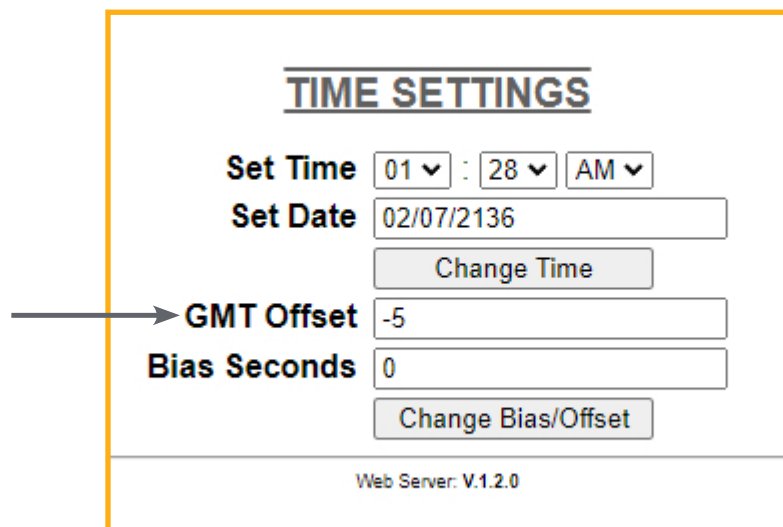

The screenshot shows the 'TIME SETTINGS' web interface. It has a title 'TIME SETTINGS' and several input fields: 'Set Time' with dropdowns for '01', '28', and 'AM'; 'Set Date' with a text input field containing '02/07/2136'; 'GMT Offset' with a text input field containing '-5'; and 'Bias Seconds' with a text input field containing '0'. There are two buttons: 'Change Time' and 'Change Bias/Offset'. At the bottom, it says 'Web Server: V.1.2.0'. An arrow points from the left to the 'GMT Offset' field.

## Before Installation - Clock Setup - Network Servers

### 3) Time Input – From Third-Party NTP Time Servers:

The clock comes pre-programmed with third-party NTP Time Servers (user changeable) accessible via the facility network and internet. These pre-programmed Time Servers can be viewed or changed in the “Network Servers” tab of the clock built-in web interface (as shown in the below image). In order to allow the clock to access the NTP Time Servers, port number 123 must be open in the facility network firewall.

The time server address text boxes in the clock’s web interface are changeable, allowing the user to delete the default third-party NTP Time Servers and program the master clock to receive time data from different third-party NTP Time Servers by typing their IP addresses or URLs into the text boxes.

### SERVER SETTINGS

<b>1st Server Address:</b> <span style="color: red;">●</span> <input type="text" value="us.pool.ntp.org"/>	<b>Server Performance</b> EXCELLENT ←
<b>2nd Server Address:</b> <input type="text" value="ca.pool.ntp.org"/>	EXCELLENT
<b>3rd Server Address:</b> <input type="text" value="uk.pool.ntp.org"/>	EXCELLENT
<b>4th Server Address:</b> <input type="text" value="jp.pool.ntp.org"/>	EXCELLENT
<b>5th Server Address:</b> <input type="text" value="ru.pool.ntp.org"/>	EXCELLENT

**Rotate Servers:**       **Server Performance**

**Network Sync Every:**  v

	1-20% POOR
	20-40% SATISFACTORY
	40-60% FAIR
	60-80% GOOD
	80-100% EXCELLENT

←

Web Server: V.1.2.0

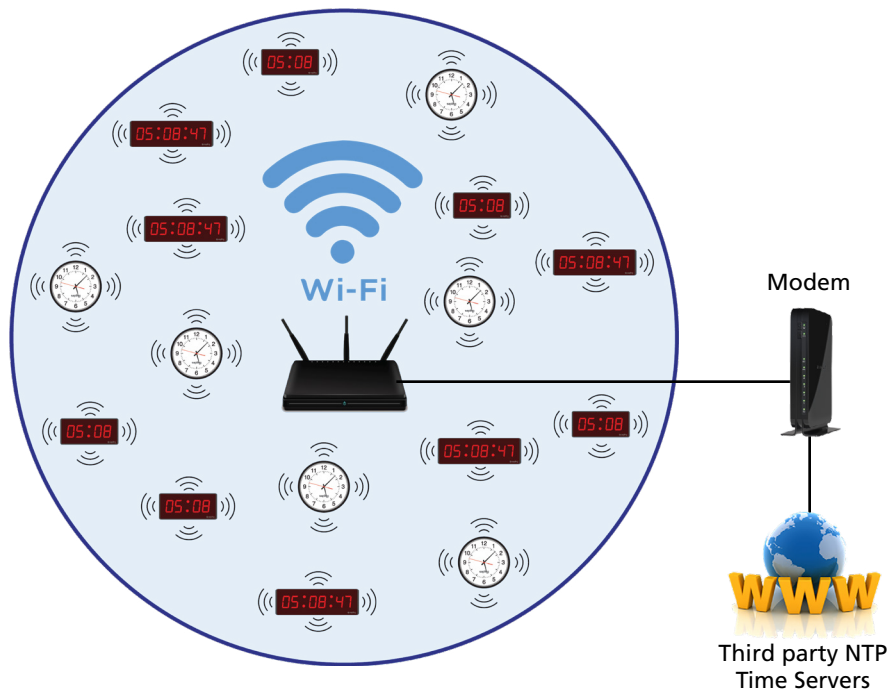

## Before Installation - Clock Setup - Network Servers

### Time Input – From an In-House NTP Time Server or from a Master Clock

If the facility has their own in-house NTP Time Server or a master clock capable of providing time data to the Wi-Fi clocks, the clocks should be programmed accordingly. To set the clocks to receive the time data from the in-house time source, please follow the below steps:

- Set the in-house NTP Time Server or master clock (capable of providing time data to the IP clocks) with a static IP address.
- Once the IP address of the in-house time source has been identified, program it in the clock “1st Server Address” text box in the “Network Servers” tab of the clock built-in web interface.
- Make sure to click the circle next to the “1st Server Address” text box, which will command the clock to take time data from this selected time source.
- Make sure that the option “Rotate Servers” is **not** selected, which commands the clock to receive time data from the “1st Server Address” as long as it is active.
- Regardless of what server or master clock you are using as a time source, all IP clocks must still be set with the UTC/GMT Offset and DST separately, as explained in this manual.
- If you only want the clocks to receive time data from the in-house NTP time server or from the in-house master clock, you can delete all other pre-loaded server addresses (2nd Server Address – 10th Server Address). If you leave these third-party time servers listed, they can be used as a backup to the in-house NTP time server, as long as the clocks can access the internet.

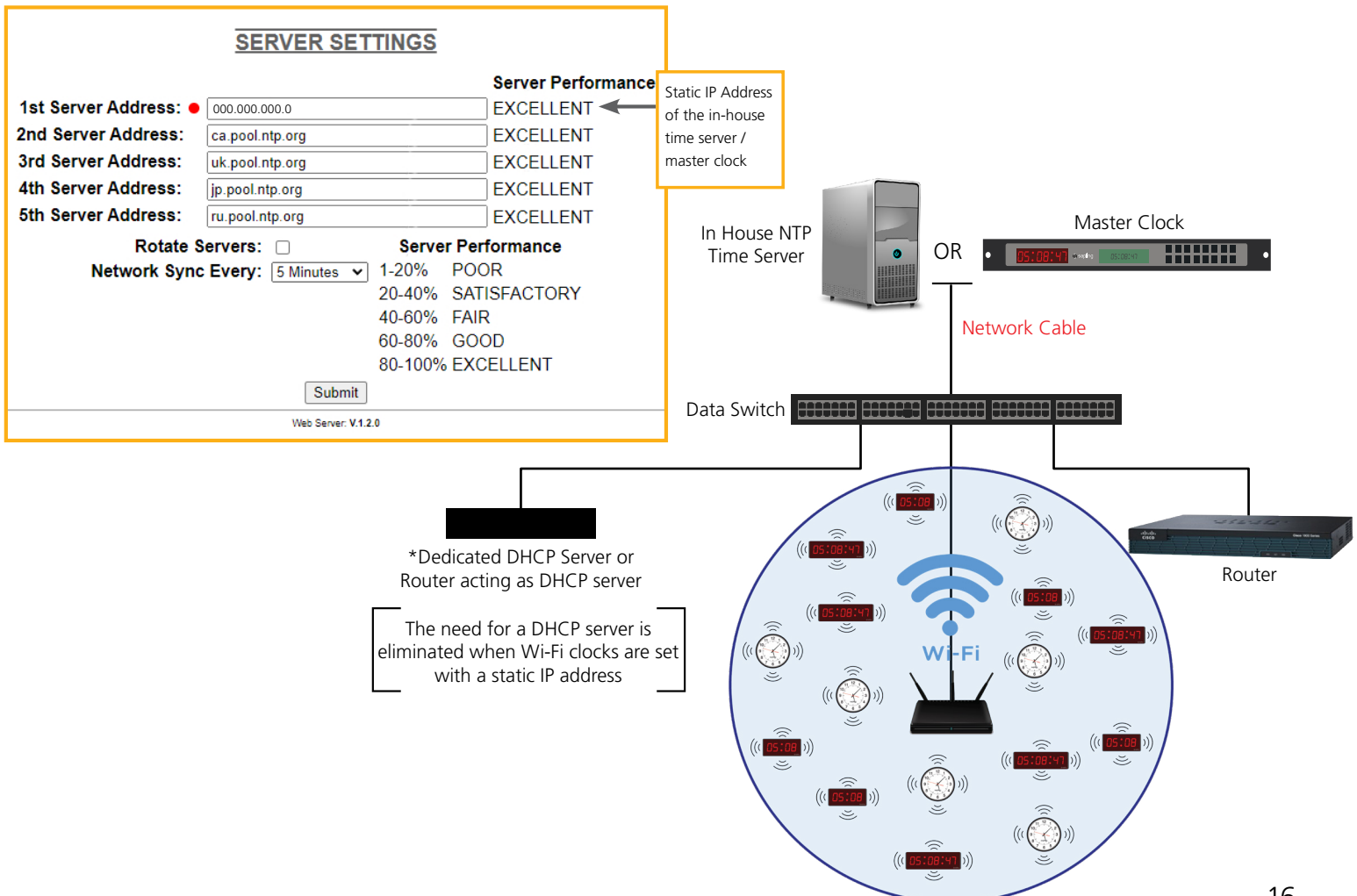



## Before Installation - Clock Setup - Network Servers

### Time Input – From two In-House NTP Time Servers or from two Master Clocks

- Set the in-house NTP Time Servers or master clocks (capable of providing time data to the IP clocks) with a static IP address.
- Once the IP addresses of the in-house time sources have been identified, program these two static IP addresses into the clock's "1st Server Address" and "2nd Server Address" text boxes in the "Network Servers" tab of the clock's built-in web interface.
- Delete all other Server Addresses that came pre-programmed in the clock and make sure to leave only the two IP addresses of the in-house time sources that you have programmed into the clock.
- Make sure that the option "Rotate Servers" is selected, which commands the clock to rotate between the two time sources.
- Regardless of what server or master clock you are using as a time source, all IP clocks must still be set with the UTC/GMT Offset and DST separately, as explained in this manual.

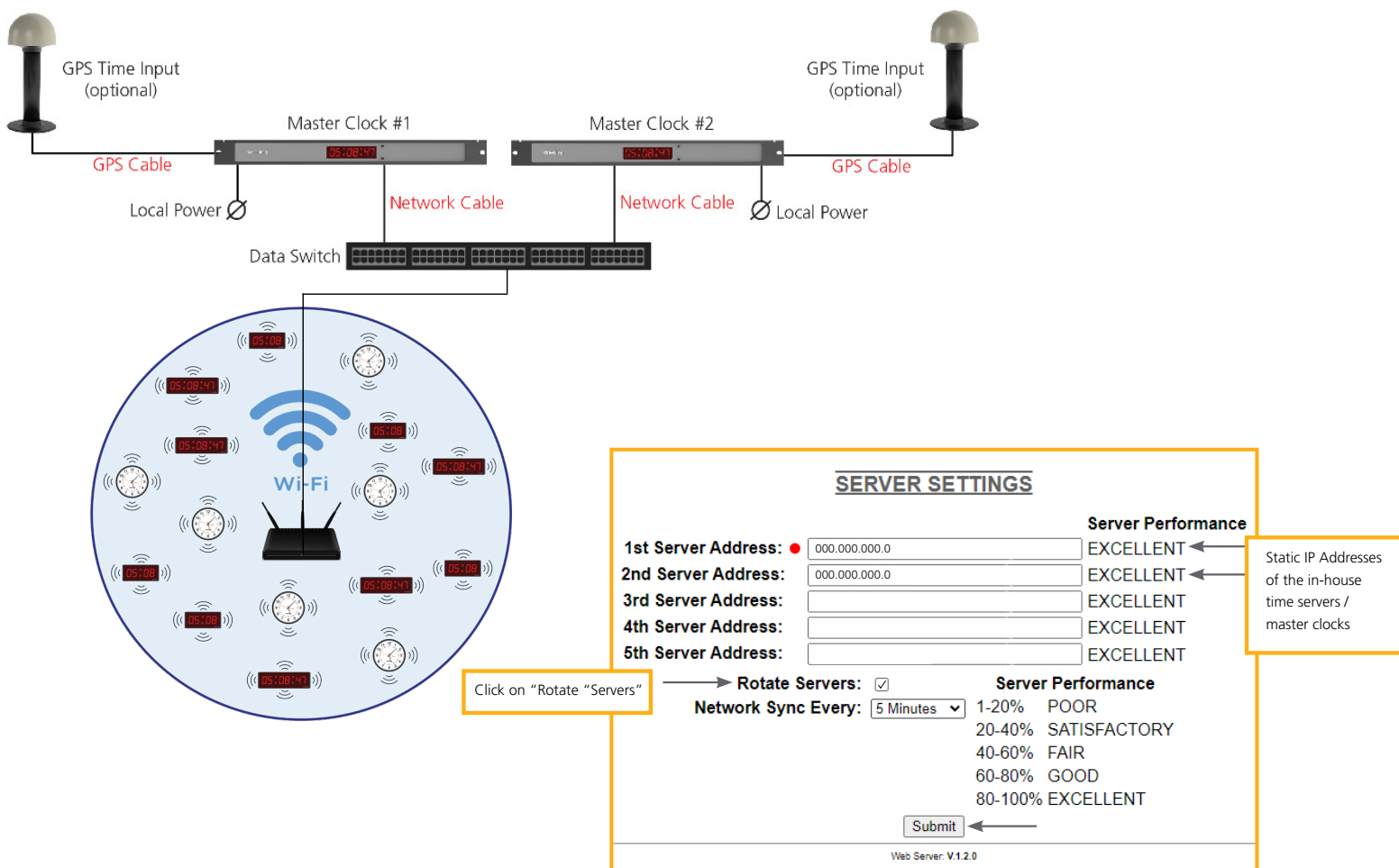

4) Close the web interface and IP monitor. The clock should now be able to accurately display time when connected to your network. More information on selectable IP clock settings are provided later on in this manual.

---

## Preparing for the Installation

---

Consideration should be made for various factors such as their location, type of mounting (surface, dual-faced or flag mounted), electrical wiring run, and more. Please read the manual including all relevant sections for your specific installation configuration to understand the steps, how to wire, and how to install the clock. In addition, please note what hardware you may need to supply.

The clock can be **Surface (wall) Mounted, Dual-Faced** or **Flag Mounted**.

Mounting the clock housing for these different configurations is different from one another; however, clock display installation and wiring is similar. Therefore, each mounting will have its own initial installation instructions section followed by a "**Uniform Stage Installation**" section.

**For installing the clocks, the installer will need to have the below items which are not provided with the clocks:**

- A #2 Phillips-head screwdriver
- Electrical wires for power (Recommended 12, 14 or 16 AWG)
- A drill and a drill bit (size depending on wall anchor)
- A flat-head screwdriver

**In Addition:**

**For a Surface (wall) Mounted Clock:**



- A double gang (utility) box

**For a Dual-Faced or a Flag Mounted Clock:**

- A double gang (utility) box
- There are 4 holes in the pole base plate that would accommodate size #8 screws for fixating it to the ceiling or to the wall. Hardware to fixate the pole base plate to the ceiling or to the wall depending on the type of wall is to be provided by the installer.

## Wall Mounted Clock Mechanical Installation

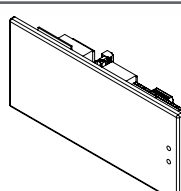
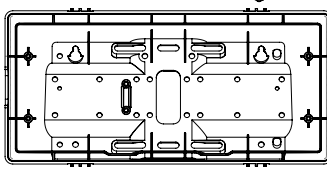
### Included in Package

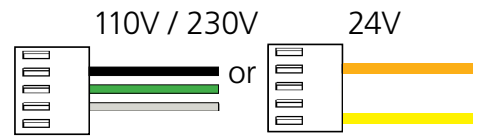
Description	Quantity	Picture
SBW Digital Clock	1	
Digital Clock Wall Housing	1	
#6-19x1/2 screw	4	
#6-32x1 screw	4	
Included with the Clock Wiring Kit		
Power/grounding wires and connector	1	 <p>110V / 230V or 24V</p>

If not mounting the clock to a double gang box, the installer needs to provide:

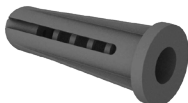
#8 self-tapping screws	4	
Wall anchors	4	

## Wall Mounted Clock Mechanical Installation

1) The digital clock surface (wall) mount housing is designed with numerous holes for the purpose of fixating it to the wall. There are two ways to mount the clock housing to the wall. Option one (the most common way) is to screw the digital clock housing to a double gang box, while the second option is to utilize its keyhole mounting holes.

**Option 1:**  
 Installing to a double gang box  
 (go to step 2)

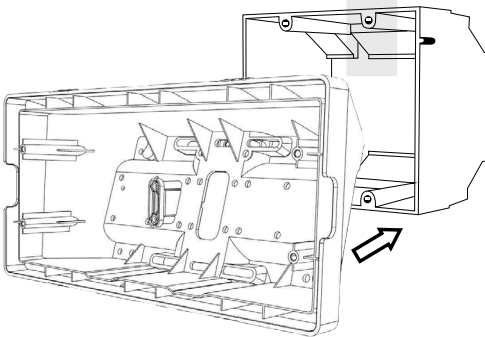

**Option 2:**  
 Installing using keyholes  
 (go to step 6A)

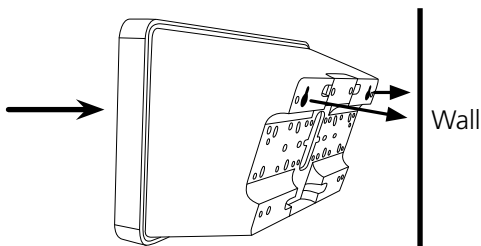

2) When installing the clock housing to a double gang box, leave at least 4 inches between the top of the gang box and ceiling. Confirm that the bottom of the gang box is level with the floor.

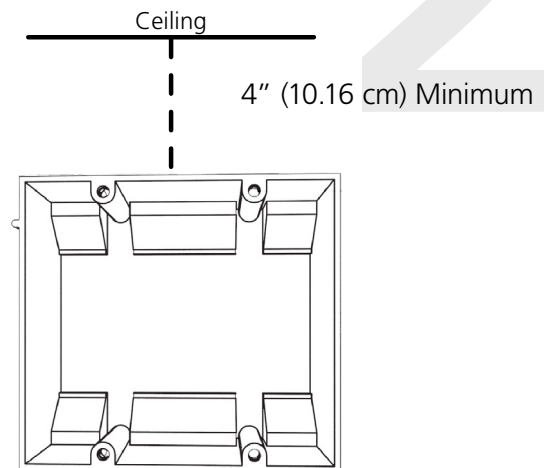

3) Run power wiring to the gang box.

4) Attach the power wires from your kit to the power wires in the gang box.

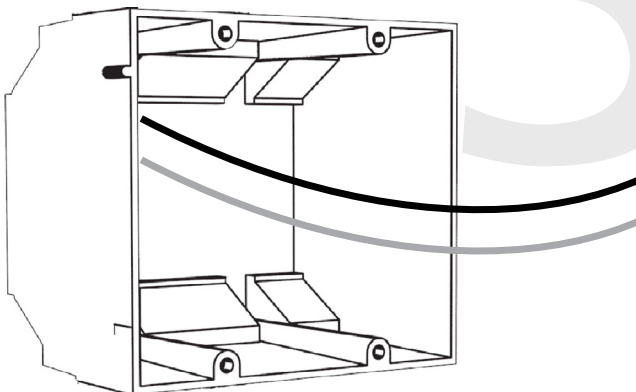

## Wall Mounted Clock Mechanical Installation

5) If you do not wish to attach the housing to the gang box, proceed to step 6A. Otherwise, go to step 7.

6A) If you do not wish to attach the housing to a gang box, place the clock housing on the wall. Leave at least 4 inches between the top rear edge of the housing and ceiling. Confirm that the bottom of the mounting piece is level.

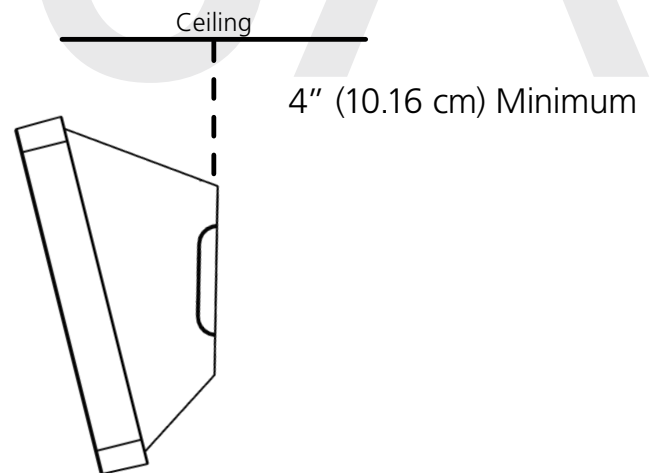

6B) Identify the keyholes towards the top of the back of the clock housing. Use a pencil to mark the top of each keyhole onto the wall, then use the 1/4 inch drill bit to drill holes at the locations of the two marks.

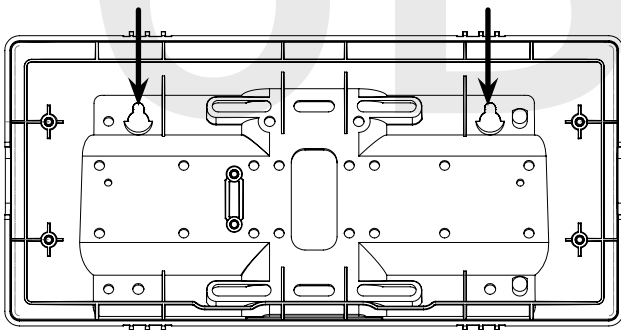

6C) Insert the wall anchors into the two holes, then place a #8 self-tapping screw into each wall anchor, leaving at least a 1/8" gap between the top of the screw and the wall.

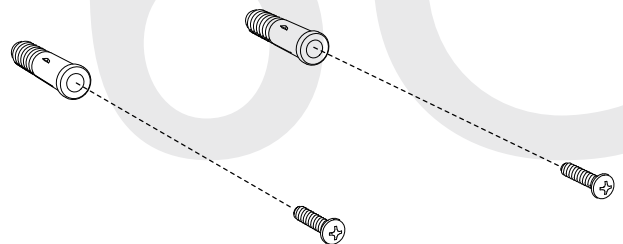

## Wall Mounted Clock Mechanical Installation

6D) Use the keyholes in the back of the housing to hang the clock onto the screws.

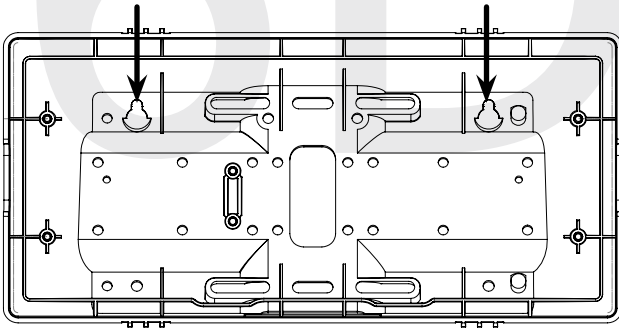

6E) Use a pencil to trace the holes beneath each keyhole onto the wall as shown in the below image. Take the clock housing off the wall, drill holes at the marked locations, and add another two wall anchors.

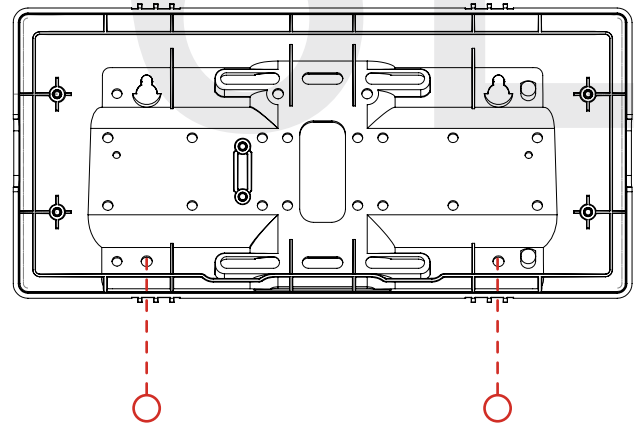

6F) Place the housing back on the wall in order to screw a second pair of #8 screws through the bottom holes and secure them in the remaining two wall anchors. This is to fixate the clock housing to the wall.

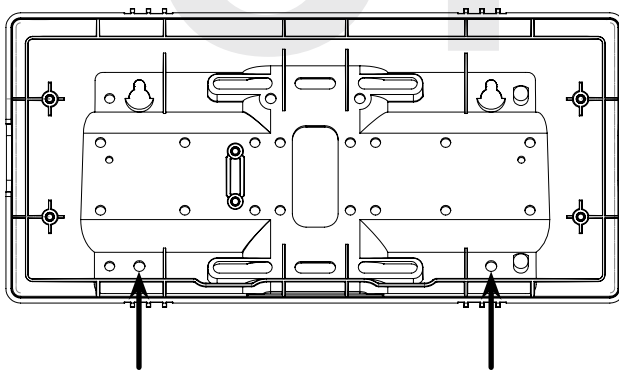

7) Run power wires through the large hole in the back of the housing. Secure the wires by passing them through the wire clamp. The wire clamp is mounted in the clock housing and can be opened by using a Phillips head screwdriver.

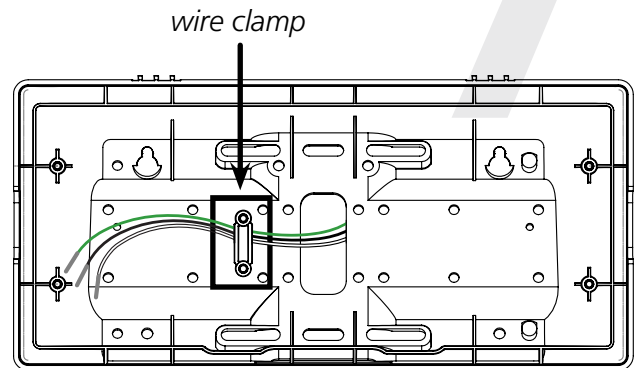

## Wall Mounted Clock Mechanical Installation

8) Attach the housing to the gang box using the #6-32x1 screws.

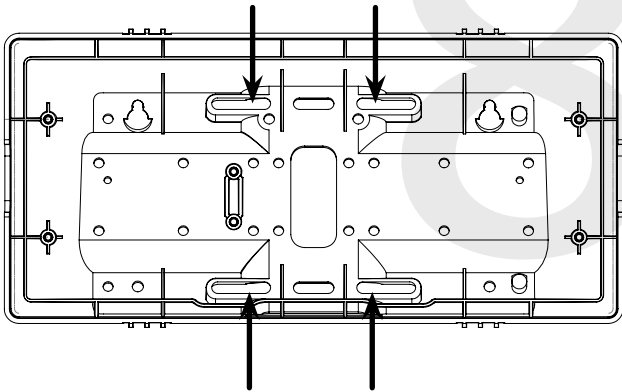

9) To proceed with the installation instructions, please follow the “**Uniform Stage Installation**” section in this manual. Once done, to complete the wall mounted clock installation, follow the below additional steps.

10) With the clock powered and properly functioning, the next step would be to remove the adhesive clear protective film from the clock filter, as shown in the below image.

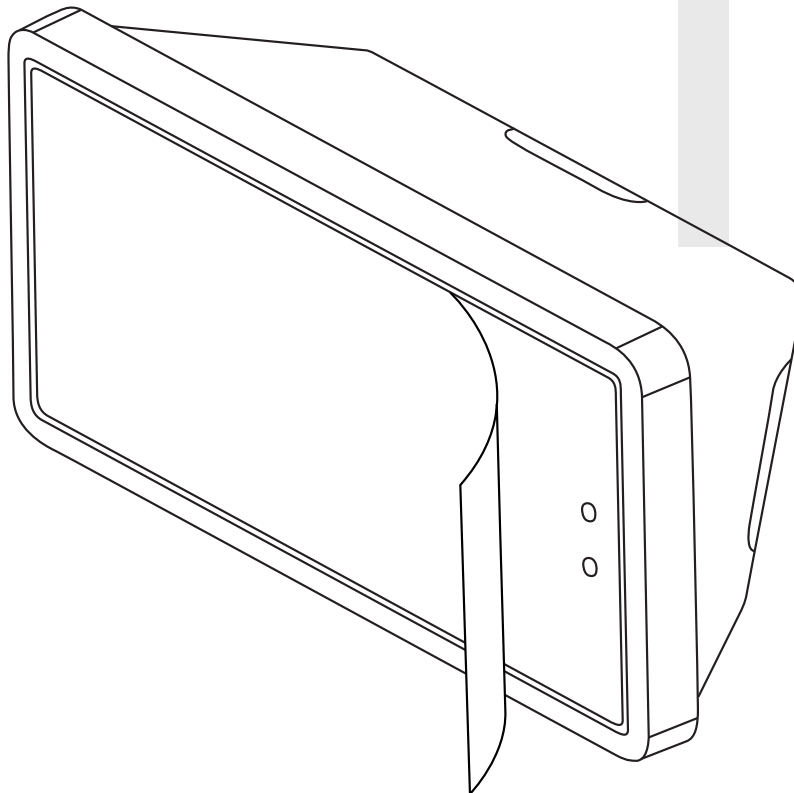

---

## Dual-Faced / Flag Mounted Digital Clocks Overview

---

### Dual-Faced Digital Clocks:

A dual-faced digital clock configuration will consist of one (1) pole and two (2) clocks suspended from the ceiling or from the wall. The mounting pole is available for the 2.5" or 4.0" digital clocks and is offered at two different lengths. The standard pole height allows ceiling or wall mounted configuration, while the short pole height is meant for ceiling mounting only and used at locations with low ceiling clearance. Part numbers and the heights for the standard or short pole can be found in their specifications.

### Dual-faced Digital Clocks:

#### Mounted from the wall:



#### Mounted from the ceiling:



### Flag Mounted Digital Clocks:

A flag mounted digital clock configuration will consist of one (1) pole and one (1) clock suspended from the ceiling or from the wall. Since the flag mounted clock utilizes the same mounting pole as the dual-faced clock, the installer should follow the installation instructions of the dual-faced clock. The following installation instructions will include two steps that are only relevant for flag mounted installation.

### Flag Mounted Digital Clocks:

#### Mounted from the wall:











#### Mounted from the ceiling:

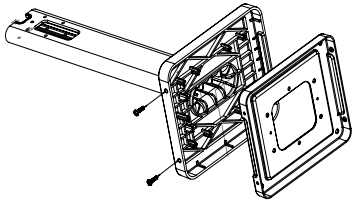



## Dual-Faced / Flag Mounted Clock Mechanical Installation



### Included in the Mounting Pole Package

Description	Quantity	Picture
Mounting Pole (including Mounting Base Plate)	1	
#10-32x3/8 green grounding screw (comes already screwed on the pole base plate)	1	
#6-32x1/2 Phillips round head black screw (comes already screwed on the pole base plate)	2	
#8-32x7/16 Phillips round head black screw	8	
#8 Internal-tooth lock washer	8	
#6-32x1 Phillips round head silver screw	4	
Flag Mount End Cap (only used in flag mount configuration)	1	
#6-32x1/4 Phillips round head silver screw (not used in this configuration)	2	

Continued on next page

If any of the items listed in the kit are missing, you may contact your dealer and order a replacement kit.

## Dual-Faced / Flag Mounted Clock Mechanical Installation

#6-19x7/16 Phillips round head black screw (not used in this configuration)	10	
#6-32x5/16 Phillips round head silver screw (not used in this configuration)	6	
#6 Internal-tooth lock washer (not used in this configuration)	6	

If any of the items listed in the kit are missing, you may contact your dealer and order a replacement kit.

If not mounting the clock to a double gang box, the installer needs to provide:

#8 self-tapping screws	4	
Wall anchors	4	

## Preparing for the Dual-Faced Installation

The mounting pole has been designed to be installed on a double gang box, which will hold the mounting pole and the dual-faced clocks. As such, to install a dual-faced clock, there is a need to have the double gang box fixated and secured to the ceiling and/or to the wall and have the power wires pre-wired in the facility's wall (or ceiling) and ready to be connected to the clock.

## Dual-Faced / Flag Mounted Clock Mechanical Installation

1) Install the double gang box in the wall or ceiling. If you are installing the gang box in the wall, leave at least eleven inches between the top of the gang box and the ceiling. If you are installing the gang box in the ceiling, leave at least eleven inches between the gang box and the wall. This space is needed to allow proper clearance when mounting the clock. The gang box should be installed level with the wall and ceiling.

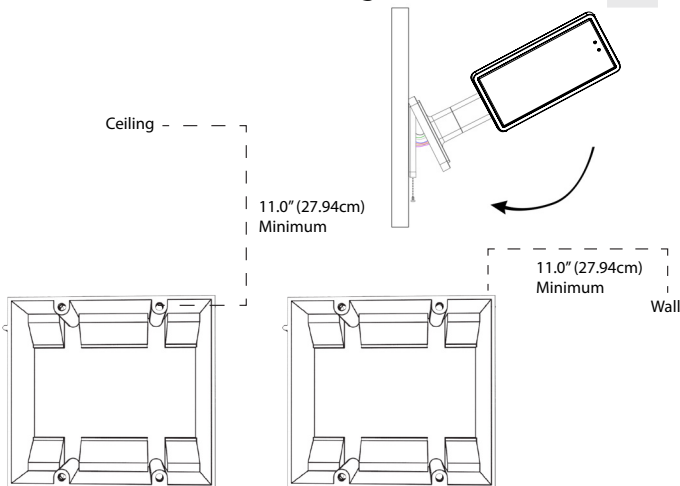

2) Run power wiring to the gang box.

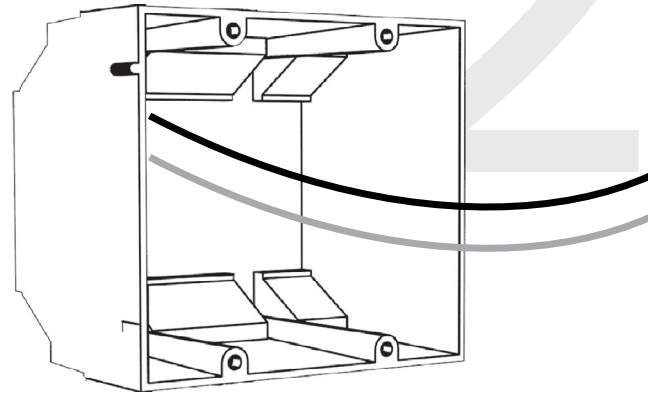

3) The mounting pole consists of a detachable metal mounting plate. The mounting plate detaches from the mounting pole by unscrewing the two #6-32x1/2 Phillips round head black screws that come already screwed on the pole base plate. Set the screws and pole aside for later.

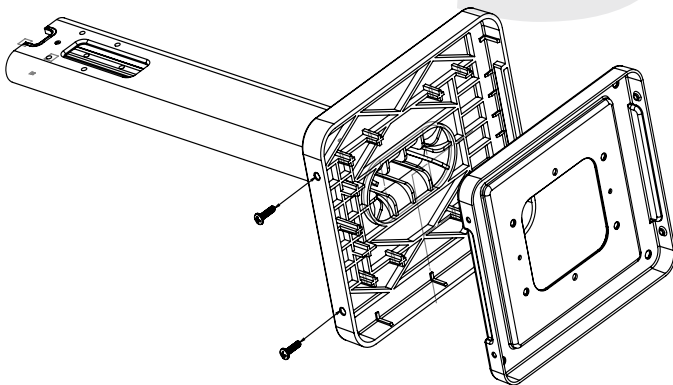

4) Attach the mounting plate to the gang box using only two of the four long, silver #6-32x1 screws. With the mounting plate as a guide, use the pencil to mark the locations of the four larger holes at the outer corners of the base plate as shown in the image below.

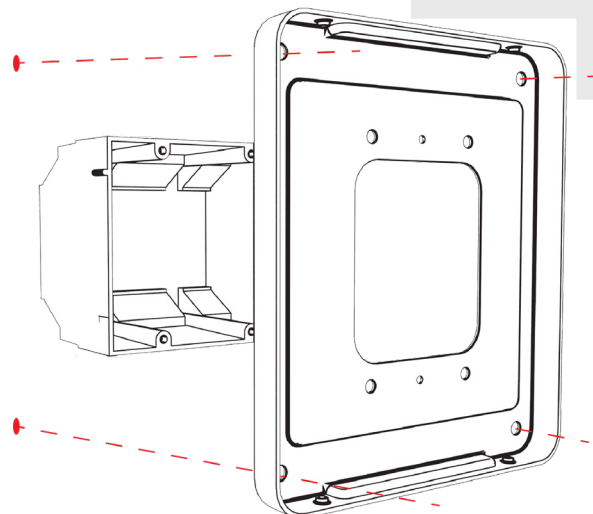

## Dual-Faced / Flag Mounted Clock Mechanical Installation

5) Remove the mounting plate and drill the four holes that were just marked in the previous step. Insert the four wall anchors into the holes.

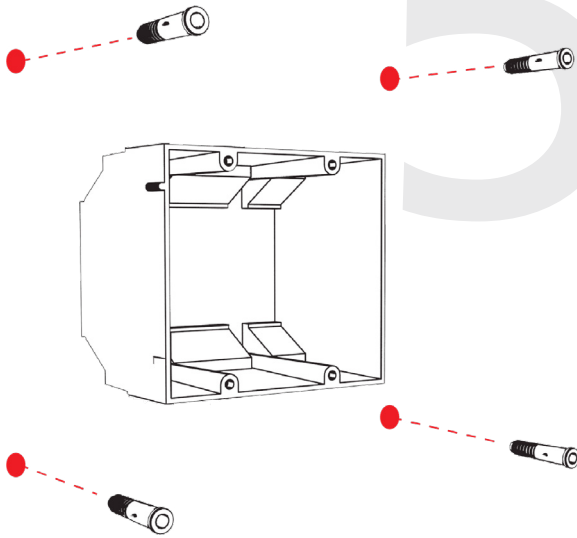

6) Reattach the mounting plate to the double gang box, this time using all four long, silver #6-32x1 screws. Then insert the four #8 screws (provided by the installer) through the mounting plate and into the anchors.

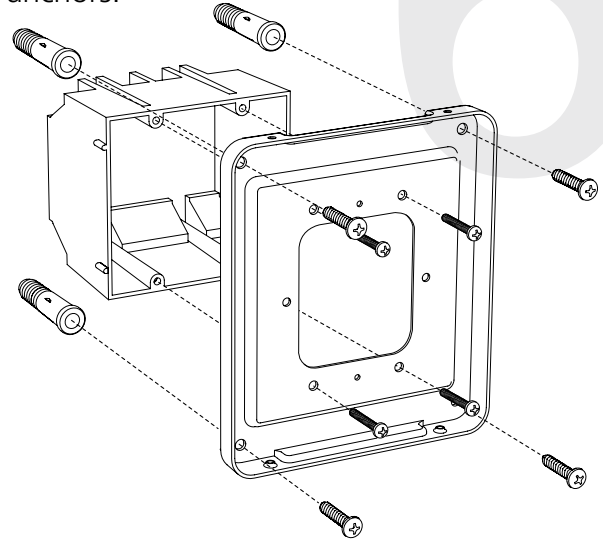

7) Thread any wiring through the mounting plate, and attach a grounding wire to the mounting plate using one of the larger centered holes and the #10-32x3/8 green screw.

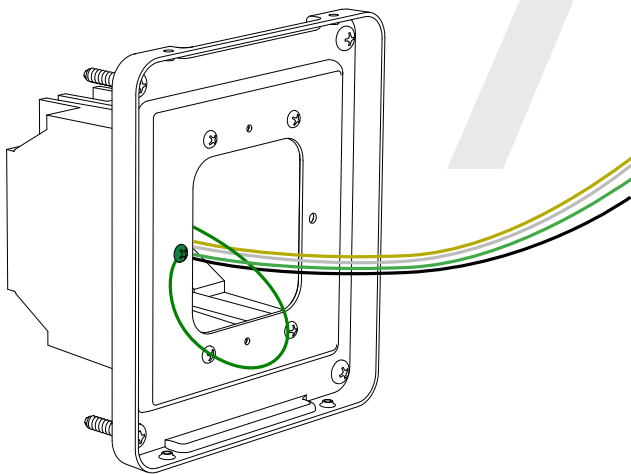

## Dual-Faced / Flag Mounted Clock Mechanical Installation

8) If the clock is to be mounted to the pole and suspended from the ceiling, then the top end cap is to be removed. If the clock is to be mounted to the pole and suspended from the wall, one of the side end caps is to be removed. For doing so, use a screwdriver to remove one of the end caps located on the back of the digital clock housing based on the orientation of the digital clock that will be attached to the pole. The end cap and screw that was used to secure it will not be needed again during this installation.

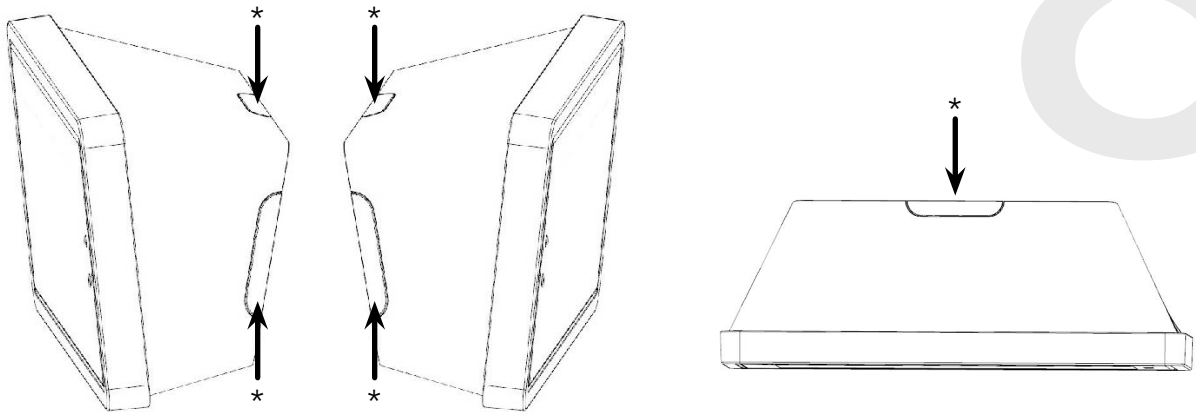

\* = end caps

9) Removing the end cap from the clock housing will allow to place the pole flush with the back of the clock housing. Position the pole so its allocated mounting holes are aligned with the clock housing. Once in position, use the four #8-32x7/16 screws and the internal-tooth washers to mount the clock housing to the pole using a Philips screwdriver. For a dual-faced clock, repeat the same with the second clock housing so both back clock cases are mounted to the pole.

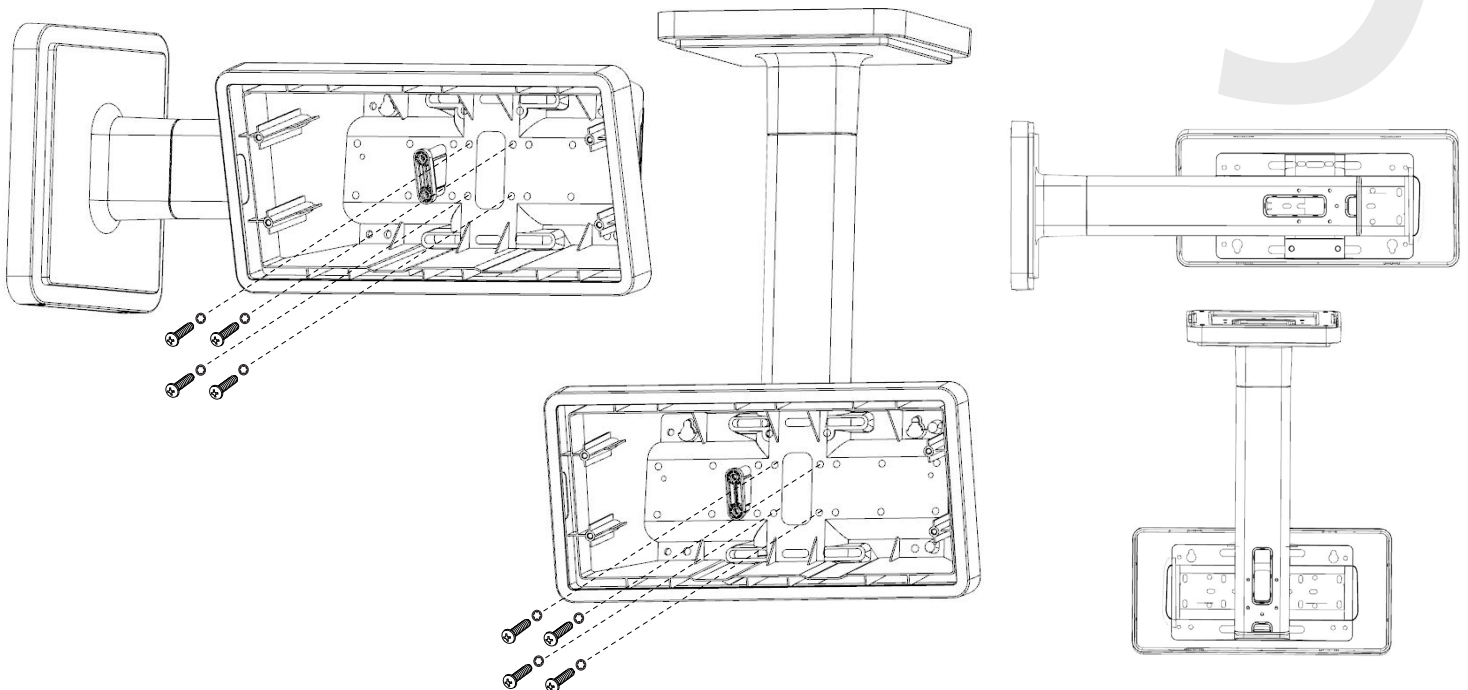

## Dual-Faced / Flag Mounted Clock Mechanical Installation

10) **For Dual-Faced installation:** repeat step 9 for attaching a second clock to the other side.

**For Flag Mount installation:** follow the below two steps.

- Instead of mounting and running two sets of wires for two clocks, there is a need to run one set of wires to the clock and mount only one clock to the pole.
- The list of items which are included for a dual-faced clock configuration consists of a **Flag Mount End Cap**, which is not in use for a dual clock mounting configuration, but is needed for a Flag Mounted installation. After completion of the pole and clock installation, there is a need to install the **Flag Mount End Cap** by following the below additional steps:

1) Remove the mounting pole end cap and the plastic ring from one of the holes.

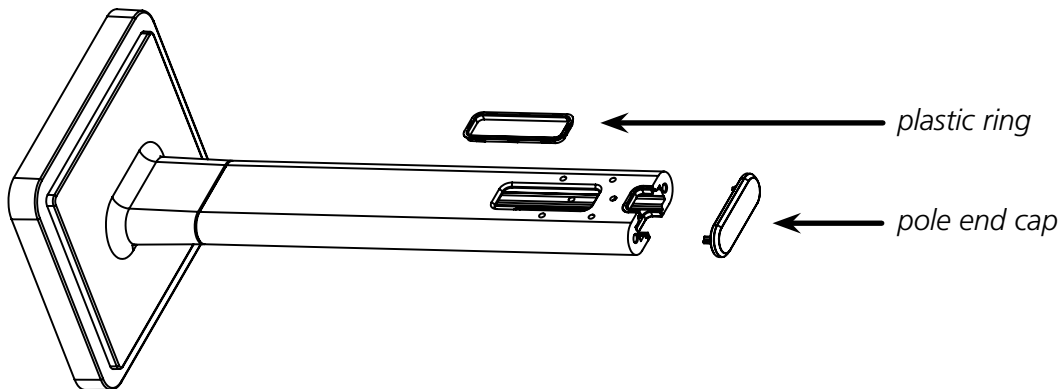

2) Attach the flag-mount end cap to the pole. Confirm that the covering flap is attached to the side where the plastic ring was removed.

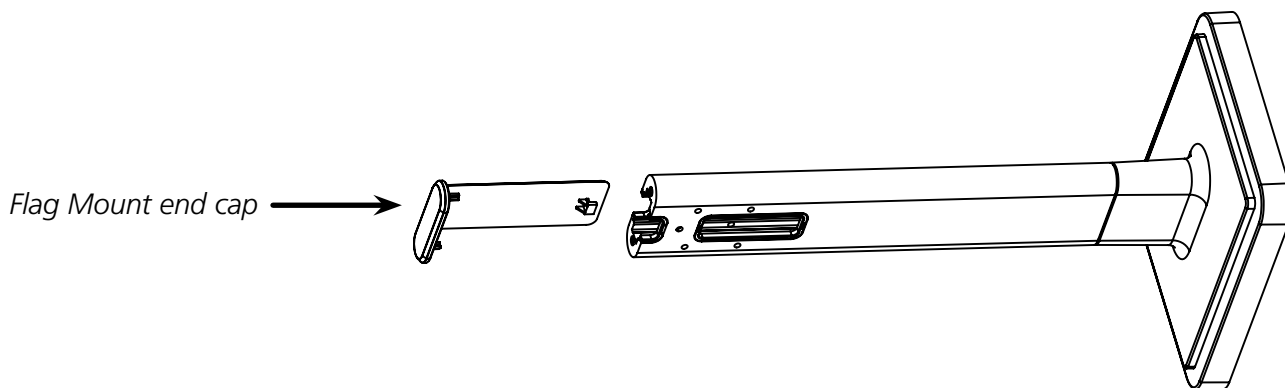

## Dual-Faced / Flag Mounted Clock Mechanical Installation

11) The standard pole length is 13.7" (34.8 cm) and the short pole length is 7.75" (19.7cm). Make sure to run electrical wires with the needed length from point A to point B, as shown in the below image. The wires are to be threaded from the gang box (through the pole base plate) into the pole, and through the hole located towards the far side of the pole and into the clock.

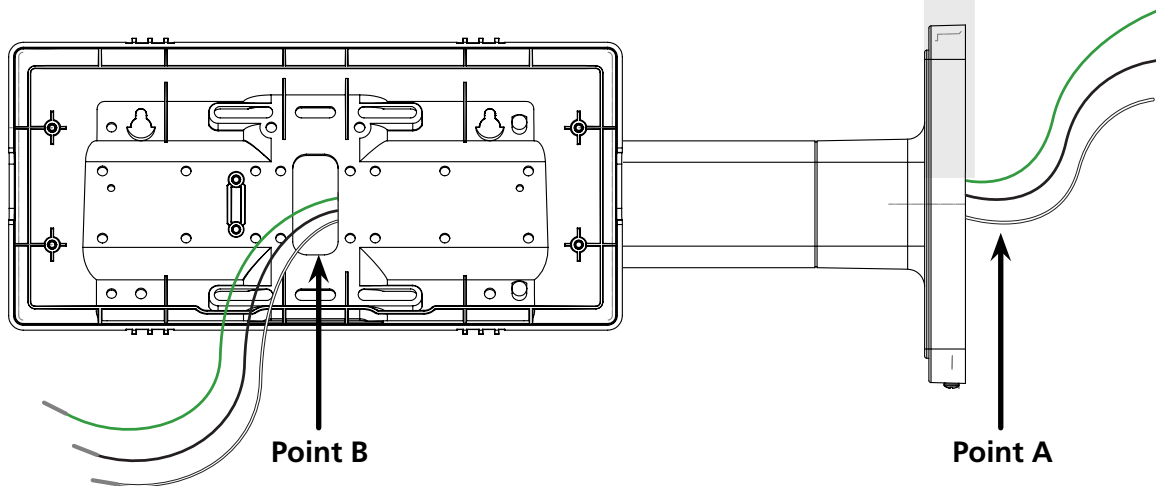

12) Once the wires are threaded through the pole and into the clock housing, use the wire clamp to secure the wires. The wire clamp is mounted in the clock housing, and can be opened by using a Phillips head screwdriver.

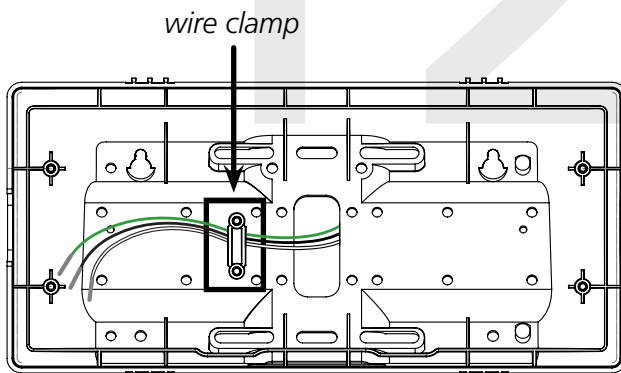

13) To proceed with the installation instructions, please follow the "**Uniform Stage Installation**" section in this manual. Once done, to complete the dual-faced or flag mounted clock installation, follow the next additional step.

---

## Dual-Faced / Flag Mounted Clock Mechanical Installation

---

14) With the clock powered and properly functioning, the next step would be to remove the adhesive clear protective film from the clock filter, as shown in the below image.

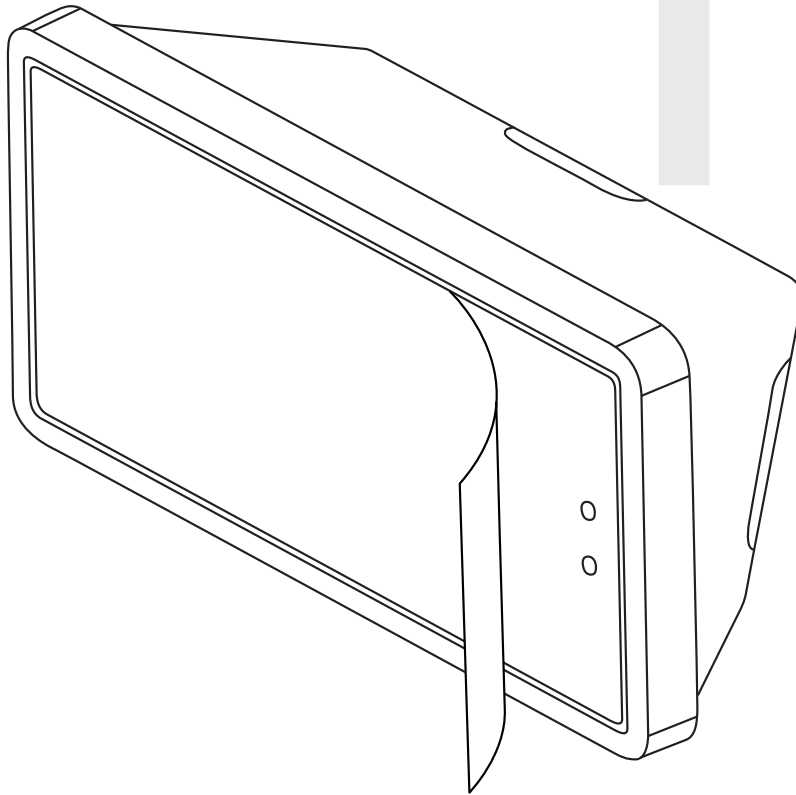



## Uniform Stage Installation

1) The Digital Clock comes with a protective filter that snaps onto the clock display utilizing four flexible tabs. Detach the filter from the clock display board by pressing inward on the filter tabs. This will allow access for screwing the display to the clock housing, which will be required in one of the next steps.

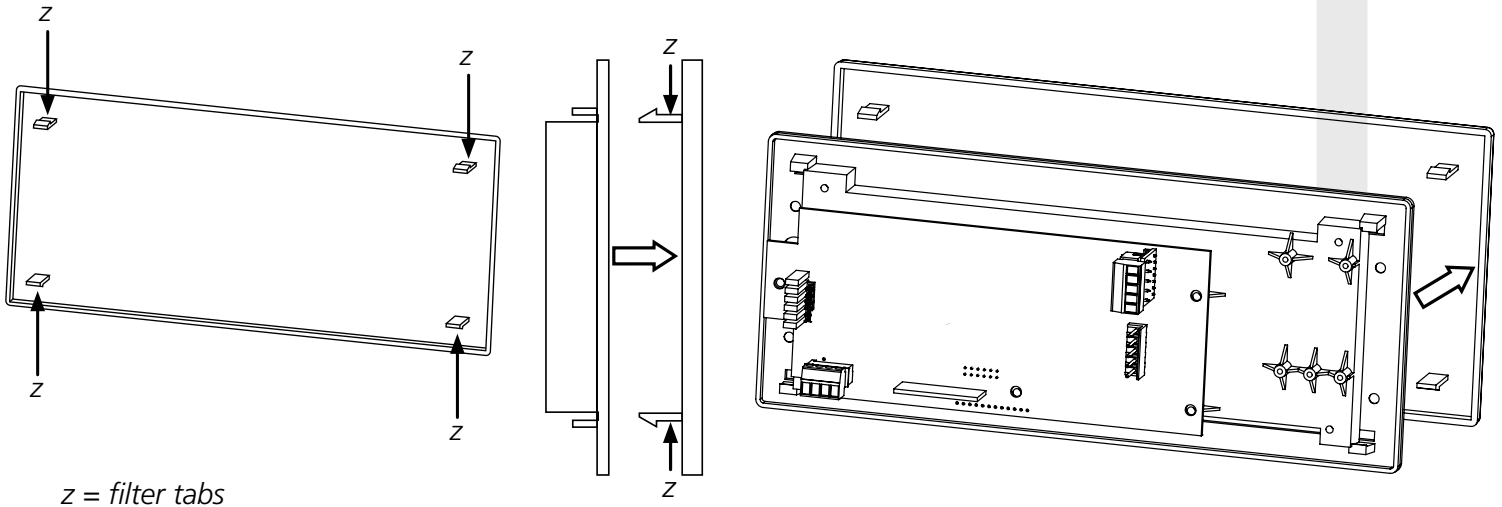

2) The clock comes with a wiring harness that will interface with the clock electric board ending with a connector. Identify the power wires coming from the wall and the wires that are coming with the clock to connect the correct wires together. To determine the wiring connection, review the wiring diagram (in this manual) that is relevant to the specific clock model. Connecting the wires together is typically done by using a wire nut.

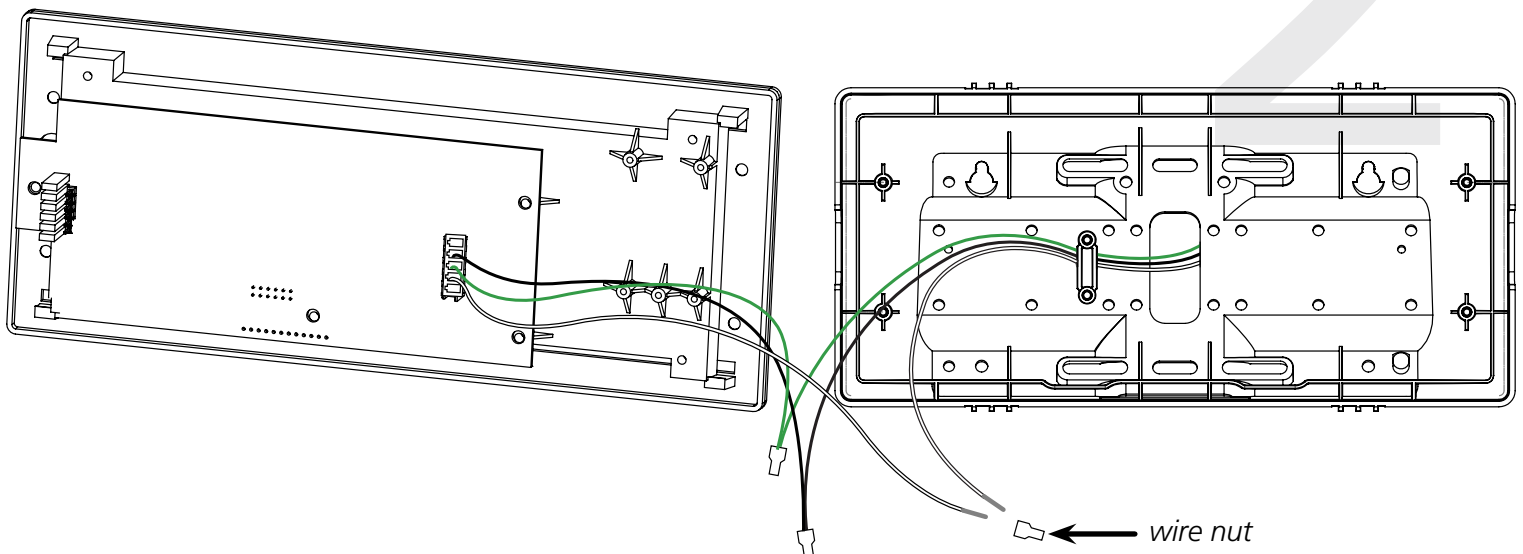

## Uniform Stage Installation

3) Depending on the clock model and accessories that may have been purchased along with the clock, additional wiring might need to be run to the clock in order to interface with the accessory (elapsed timer control panel, temperature sensor, user input, etc.). For doing so, please review the installation instructions and the wiring diagram for your specific application (and/or accessory) which can be found in this manual.

4) The next step would be to wire the clocks and use the provided connectors attaching the to the clock electric board.

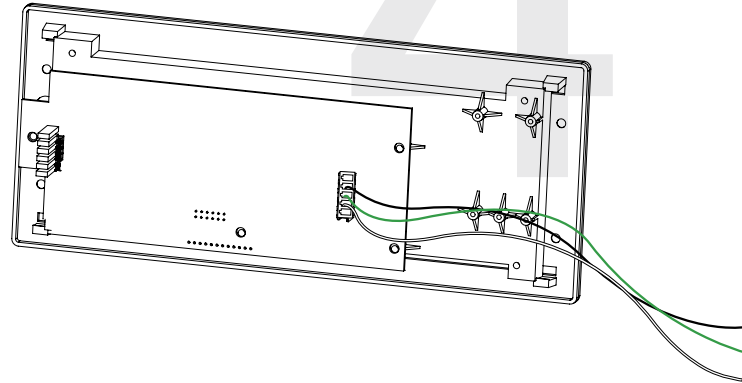

5) Use the four (4) #6-19x3/8 black flat head thread-forming screws that are provided with the clock in order to screw the display board to the clock housing.

**NOTE:** For 2.5" Digital clocks, the holes for the screws will be on the left and right inner surfaces of the housing. For 4.0" Digital Clocks, the holes will be on the top and bottom surfaces.

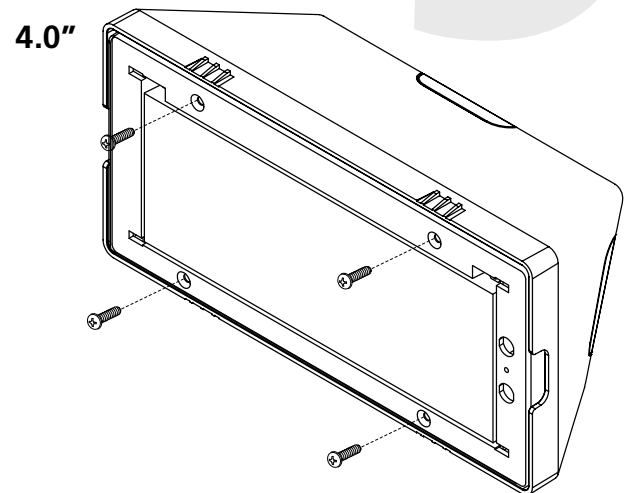
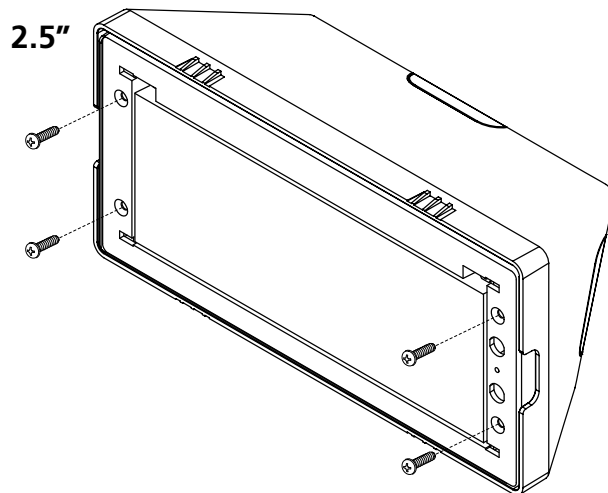

## Uniform Stage Installation

6) Remove the clear plastic protective film from the display board.

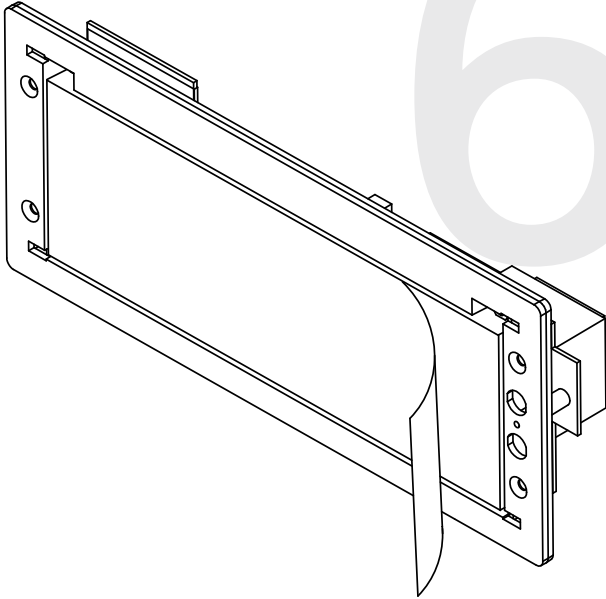

7) Place the filter over the display board by lining up the tabs with the holes. You should hear a snapping noise as the filter flex tabs latch into place.

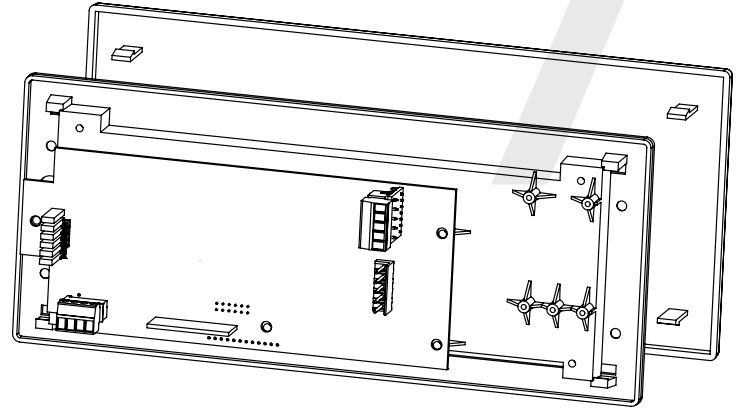

8) Once the clock receives power, it will display its software version followed by segments display testing. Once done, if the clock is receiving time data, it will present the time received. If the clock is not able to receive time data, its colons will blink and its time will be based of internal real time quartz oscillator.

---

## Re-enabling Direct Mode

---

Access to the clock can be controlled by changing the clock's connection mode. There are two modes:

### Connection Mode and Direct Mode

The clock is shipped in Direct Mode. Once a network has been set by the user, the clock will always start in Connection Mode.

The clock can be placed into Direct Mode by pressing the top button twice. If performed correctly, the word "DIRECT" will appear on the display. On a 4-digit clock, only the letters "DIRE" will appear.

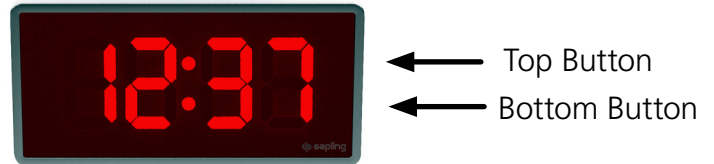

### The functions of each mode are as follows:

**Connection Mode** - In connection mode, a properly configured Wi-Fi clock is accessible over the facility's network, and will appear on a Network Monitor located on the same subnet.

**Direct Mode** - In Direct mode, a Wi-Fi clock acts as its own Wireless Access Point and can be accessed directly from any Wi-Fi capable computer in range of it. In this mode, a clock will wait four minutes for the user to access it before reverting to connection mode.

While in Direct mode, the clock will temporarily change its IP address to 192.168.240.1. It will revert to whichever IP address is listed on the Network Settings address page once Direct mode has been ended.

## Temperature Sensor Installation (3200/3300 Only)

**(IMPORTANT:** Detach clock from power source before installing new circuitry. DO NOT add new circuitry while the clock is operating)

Attach the end of the Temperature Sensor Wire to the circuit board in the following manner:

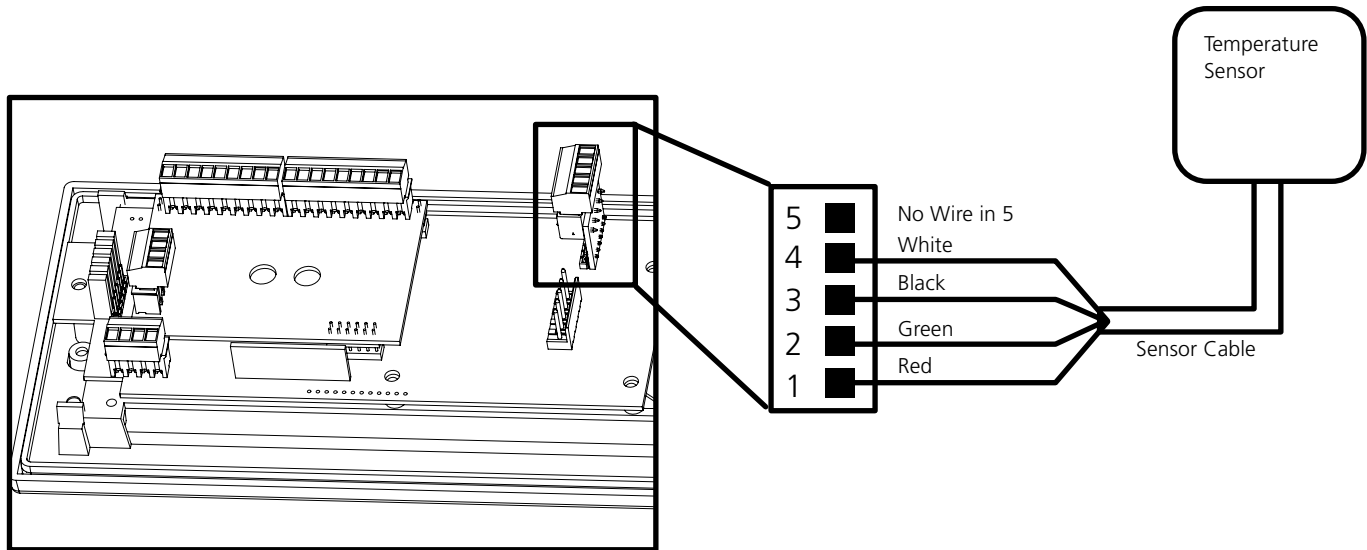

The Sensor Cable is 6 feet (1.83 meters) long, and so the sensor should be positioned within 6 feet of the clock. The cable is unshielded, 4 conductor, 22AWG (.33mm<sup>2</sup>). If longer than 6 feet is required, the wire would have to be terminated in an electrical box, and the longer wire would have to be provided by the customer.

Data from the temperature sensor will be sent to your clock when the clock is powered on. For more information on how to make the digital clock display temperature, please see the section labeled **"Web Interface - Display Settings."**

## Buzzer Installation (3300 Only)

**(IMPORTANT:** Detach clock from power source before installing new circuitry. DO NOT add new circuitry while the clock is operating)

During installation, there are two port blocks mentioned. The block on the upper-left will be called J1, while the block on the bottom left will be called J3. Refer to the diagram for details. For J1, the ports in the block are listed as 1-9, starting with port 1 on the left, and ending with port 9 on the right. For J3, the ports in the block are listed as 1-4, starting with port 1 on the bottom and port 4 on the top.

The Buzzer can be installed on the clock circuit board with four easy steps:

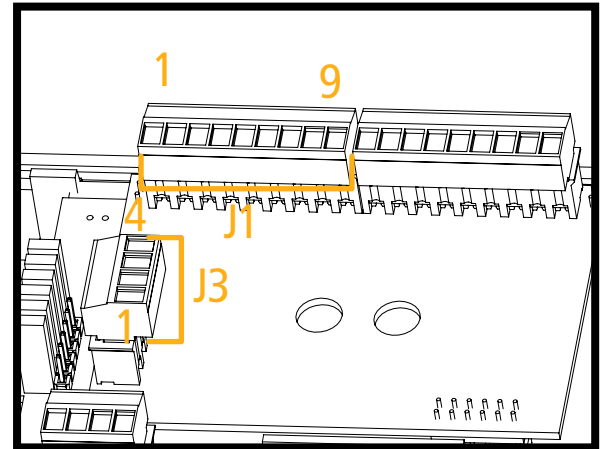

1. Attach the long green connector to the J1 Sync Input ports.
2. Confirm that the wires are attached to holes 7 and 8. The red wire should be in hole 7. The black wire should be in hole 8.
3. Attach the short green connector to the J3 Relay Output ports.
4. Confirm that the wires are attached to holes 1 and 2. The yellow wire should be in hole 1. The black wire should be in hole 2.

**To program the buzzer,** use a web browser on the same network as the clock to connect to it, log onto web interface and perform the following actions:

1. Click on the Elapsed Timer or Inputs tab.
2. Find the drop-down menu next to "On Countdown complete, close" and select "Relay 2"
3. In "for \_\_\_\_ seconds" set the amount of time that you wish the buzzer to sound when the countdown ends. The number must be a whole number from 1 to 30.
4. Press the Submit button.

For information on the Web Interface, refer to the sections labeled "**Web Interface - Elapsed Timer**" or "**Web Interface - Inputs.**"

## User Input Installation (3300 Only)

**(IMPORTANT:** Detach clock from power source before installing new circuitry. DO NOT add new circuitry while the clock is operating)

During installation, there is one port blocks mentioned. The block on the upper-right will be called J2. Refer to the diagram on the right for details. The four available inputs are assigned per the diagram below.

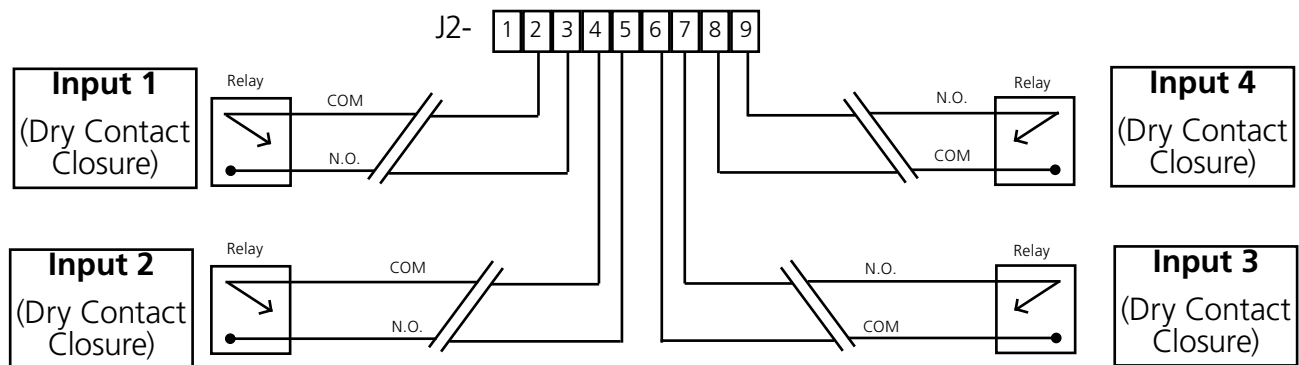
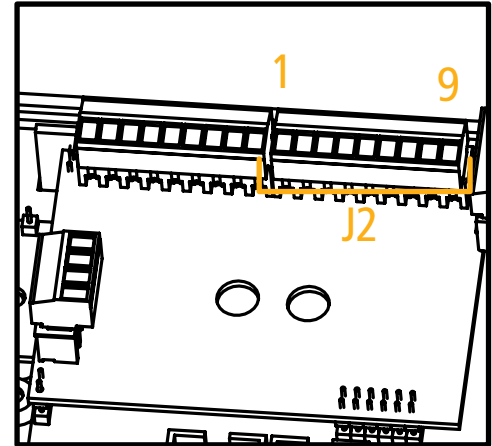

Use a dry contact closure between any of the two lines shown above to activate one of the numbered user inputs. This input is a *dry contact closure*, which means that **the user should not be providing external power on either of the lines leading from the relay to the clock.** The dry contact closure only needs to complete the circuit when activated, and can be a simple switch or button.

To configure what a given input does to the clock when activated, refer to the section of this manual labeled "**Web Interface - Inputs.**"

## Network Monitor Software - Main Screen

**YOUR COPY OF THE NETWORK MONITOR MAY HAVE ADDITIONAL COLORS OR BRANDING.**  
**THE MONITOR SHOWN IN THIS MANUAL CONTAINS NO BRANDING OR COLORS.**  
**ALL FEATURES REMAIN THE SAME.**

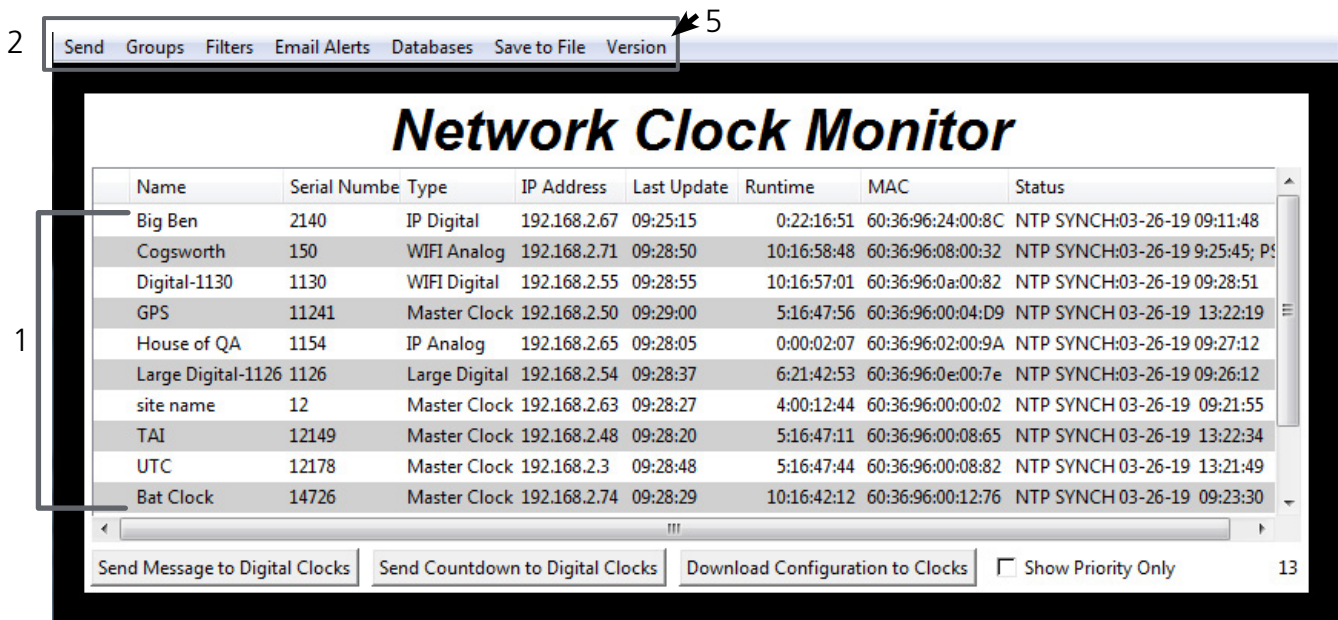

1. **Device List** - Displays all of the relevant IP devices that are active on the system subnet. The monitor screen displays the name of the clock, serial number, type of clock, IP address, last updated time, how long the clock has been running, and the status of the clock. Double clicking on a device in the device list will open the web interface for that device.

Using a right-handed mouse to right-click on any row in the Device List will open the **Quick Access Menu**. See the section in this manual labeled "**Network Monitor Software - Quick Access Menu**" for more information.

2. **Task Bar** - See the section in this manual labeled "**Network Monitor Software - Task Bar Options**"

3. **Show Priority** - By selecting this option, the IP device(s) that the user previously "marked as priority" will be the only clocks shown in the program window.

4. **Device Count** - This number is the amount of IP devices that are displayed on the Network Monitor. **The Network Monitor has two subtypes:**

**CFA - Intended for use with Wi-Fi Clocks, Master Clocks, Network Repeaters, Wi-Fi Large Digital Clocks, and Network Repeaters.**

**CFL - Intended for use with IP-PoE Digital, Wired IP Large Digital, and IP-PoE Analog Clocks. You can check the type by clicking on "Version" (5) at the top of the Monitor window.**



## Network Monitor Software - Main Screen

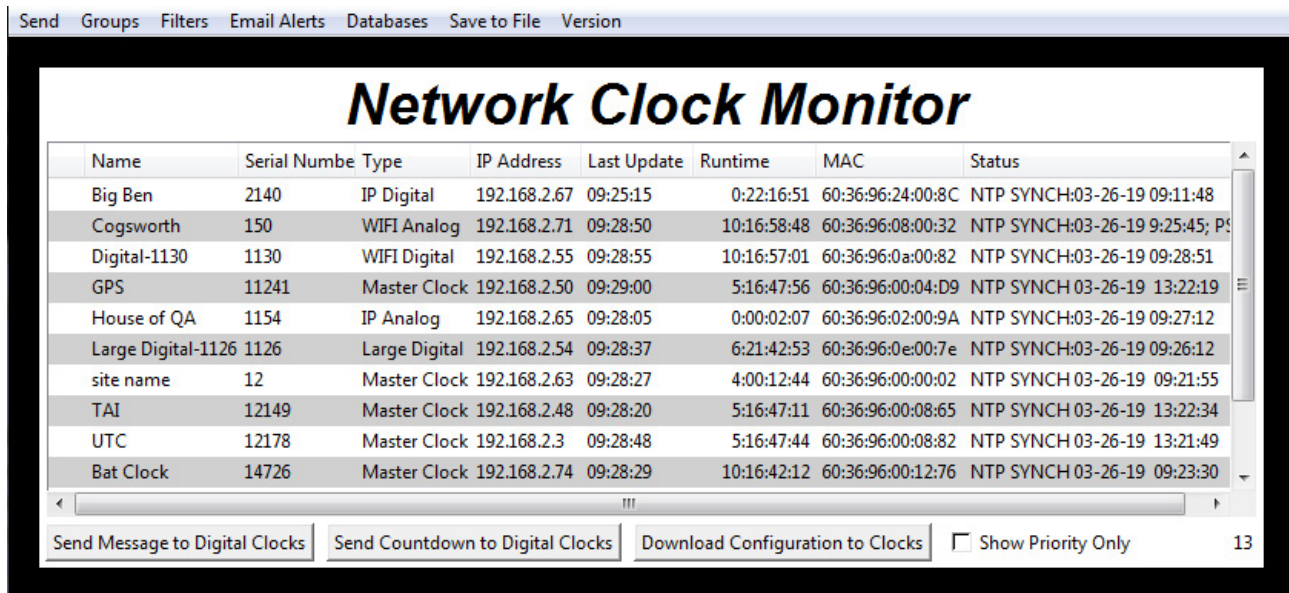

1

2

### 1. Send Message to Digital Clocks - Allows the user to generate a message that will be sent to digital clocks.

a. **Enter Password** - The default password is 6063

b. **Message to be displayed** - Lets the user enter a message to be displayed on digital clocks. Messages may consist of the digits 0-9 and the English letters A-Z. The message is generated in a font that matches its appearance on the clock, so you can preview the appearance of each message before sending it. The message will repeat ten times once sent.

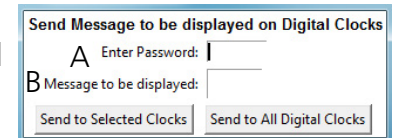

C

D

c. **Send to Selected Clocks** - Applies the message to whichever clocks have been highlighted on the Device List.

d. **Send to All Digital Clocks** - Applies the message to all IP-PoE Digital, Wi-Fi Digital, and Large Digital Clocks.

### 2. Send Countdown to Digital Clocks - Allows the user to generate a countdown that will be sent to digital clocks.

a. **Enter Password** - The default password is 6063

b. **Start values** - Enter the starting hour, minute, and second into the fields. For example, entering a 1 into each field will start a countdown from 1:01:01

c. **Send to Selected Clocks** - Applies the countdown to whichever clocks have been highlighted on the Device List.

d. **Send to All Digital Clocks** - Applies the countdown to all IP-PoE Digital, Wi-Fi Digital, and Large Digital Clocks.

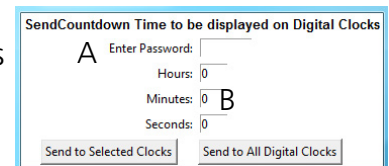

C

D

## Network Monitor Software - Main Screen

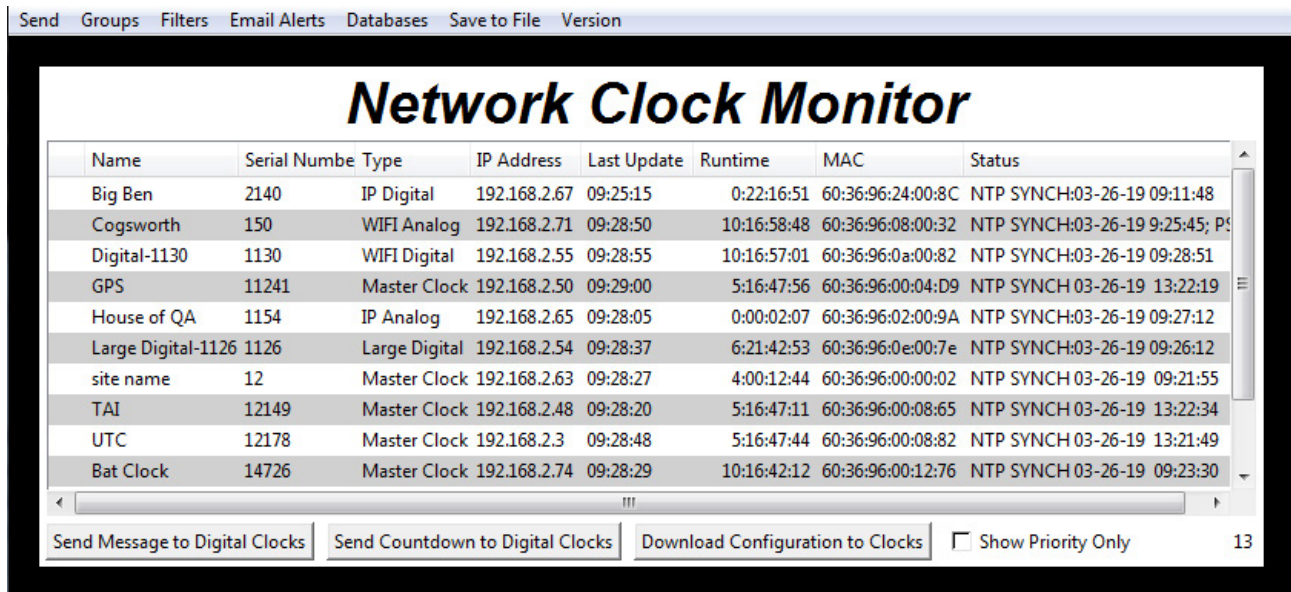

1

**1. Download Configuration to Clocks** - If a configuration file was created using "Upload and Save Configuration" on the Quick Access Menu, this option lets the user apply the configuration file to other clocks highlighted within the monitor. For more information, see the section of this manual labeled "**Network Monitor Software - Quick Access Menu.**"

Pressing this button will cause the Download Configuration window to appear:

- a. **Enter Password** - The default password is 6063
- b. **Select Configuration** - Pressing the button allows the user to browse their computer for a previously-saved configuration file.
- c. **Send to Selected Clocks** - Applies the configuration file to whichever clocks have been highlighted on the Device List.
- d. **Send to All Valid Clocks** - Applies the configuration file to all applicable devices on the Device List. For instance, an Analog IP clock configuration file would be applied to every Analog IP clock on the Device List.



C

D

## Network Monitor Software - Task Bar Options

1

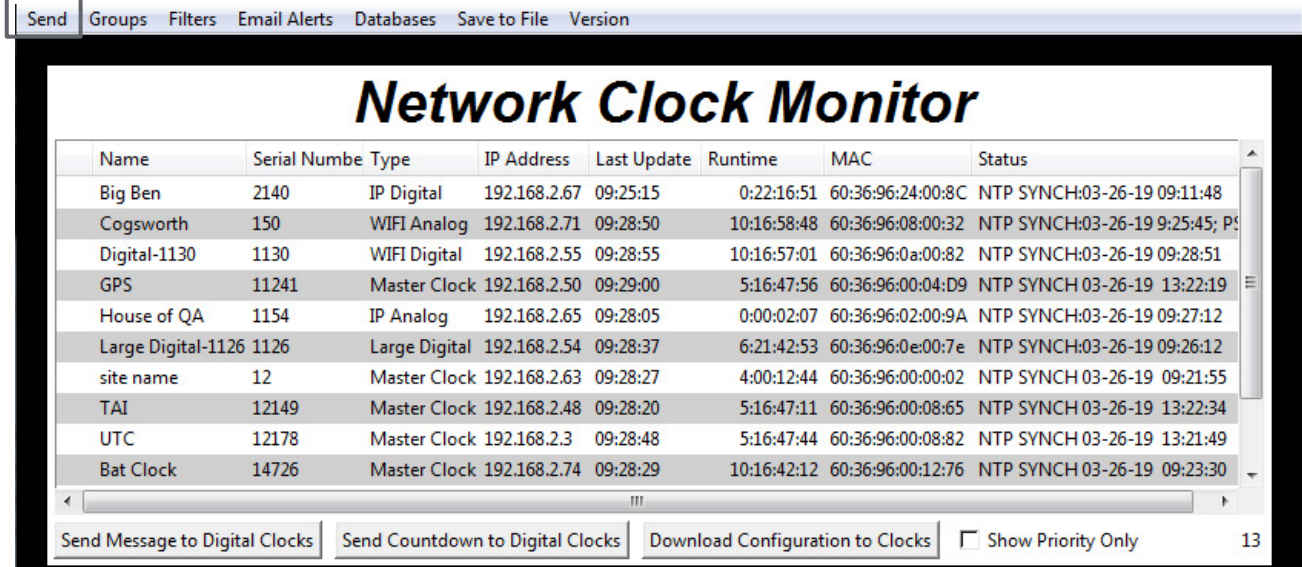

Name	Serial Number	Type	IP Address	Last Update	Runtime	MAC	Status
Big Ben	2140	IP Digital	192.168.2.67	09:25:15	0:22:16:51	60:36:96:24:00:8C	NTP SYNCH:03-26-19 09:11:48
Cogsworth	150	WIFI Analog	192.168.2.71	09:28:50	10:16:58:48	60:36:96:08:00:32	NTP SYNCH:03-26-19 9:25:45; P
Digital-1130	1130	WIFI Digital	192.168.2.55	09:28:55	10:16:57:01	60:36:96:0a:00:82	NTP SYNCH:03-26-19 09:28:51
GPS	11241	Master Clock	192.168.2.50	09:29:00	5:16:47:56	60:36:96:00:04:D9	NTP SYNCH 03-26-19 13:22:19
House of QA	1154	IP Analog	192.168.2.65	09:28:05	0:00:02:07	60:36:96:02:00:9A	NTP SYNCH:03-26-19 09:27:12
Large Digital-1126	1126	Large Digital	192.168.2.54	09:28:37	6:21:42:53	60:36:96:0e:00:7e	NTP SYNCH:03-26-19 09:26:12
site name	12	Master Clock	192.168.2.63	09:28:27	4:00:12:44	60:36:96:00:00:02	NTP SYNCH 03-26-19 09:21:55
TAI	12149	Master Clock	192.168.2.48	09:28:20	5:16:47:11	60:36:96:00:08:65	NTP SYNCH 03-26-19 13:22:34
UTC	12178	Master Clock	192.168.2.3	09:28:48	5:16:47:44	60:36:96:00:08:82	NTP SYNCH 03-26-19 13:21:49
Bat Clock	14726	Master Clock	192.168.2.74	09:28:29	10:16:42:12	60:36:96:00:12:76	NTP SYNCH 03-26-19 09:23:30

Send Message to Digital Clocks   Send Countdown to Digital Clocks   Download Configuration to Clocks    Show Priority Only   13

1. **Send** - When clicked, this button will display the following options:

**Send Message** - Performs the same action as the Send Message to Digital Clocks button. Applies only to Digital Clocks.

**Send Looping Message** - Refer to the section of this manual, "**Network Monitor Software - Quick Access Menu.**" Applies only to Digital Clocks.

**Send Countdown** - Performs the same action as the Send Countdown to Digital Clocks button. Applies only to Digital Clocks.

**Find Hands** - Commands Analog Clocks to resynchronize their hands. The user will be prompted to enter a password to authenticate their permissions. This command can be sent to one analog clock, a selected group of analog clocks, or all of the analog clocks in the system. Applies only to analog clocks.

## Network Monitor Software - Task Bar Options

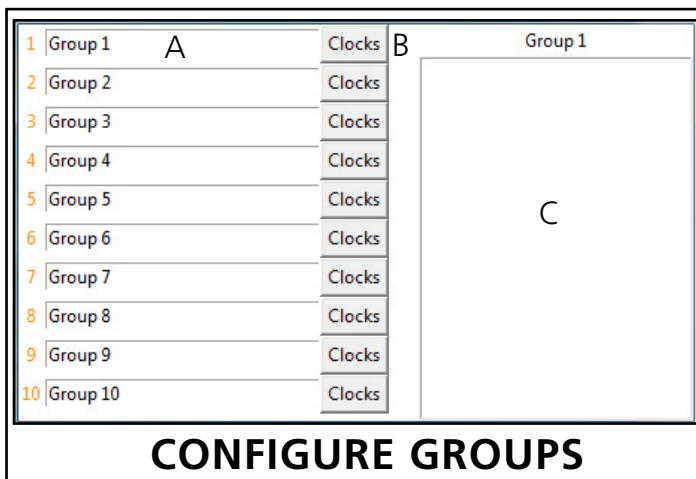
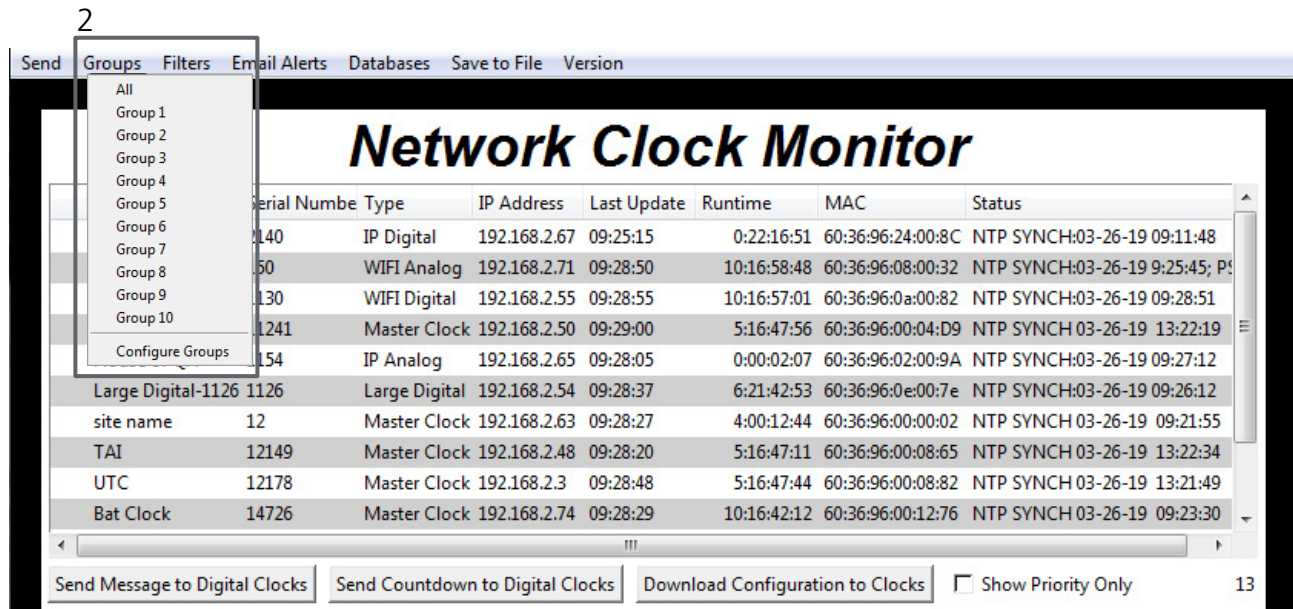

**2. Groups** - When clicked, this button will open the Groups drop-down menu.

**All** - Clicking on this option will cause the monitor to display all compatible IP devices on the network.

**"Group Name"** - Clicking on the name of a group will cause the monitor to display all of the IP devices in that group. Example: Clicking on "Group 1" will cause the monitor to show only the devices that have been added to Group 1 through the Configure Groups menu.

**Configure Groups** - Opens the group configuration menu (see left).

A. **Text Boxes** - Entering a name into the text box will change the name of the group. For example, the first text box currently contains the name "Group 1". This will cause the first group to be shown as "Group 1" in the drop-down menu.

B. **Clocks buttons** - Clicking on a Clocks button will display each of the group's devices in the box to the right.

C. **Device Box** - Displays the devices for the selected group. The name of the selected group will appear above the device box.

To add a device to the group, click on a device on the Network Monitor. While holding down the button on the mouse, drag the name of the device over to the device box, then release the button on the mouse.

To remove a device from the group, click on a device in the device box. While holding down the button on the mouse, drag the name of the device outside of the device box, then release the button on the mouse.

## Network Monitor Software - Task Bar Options

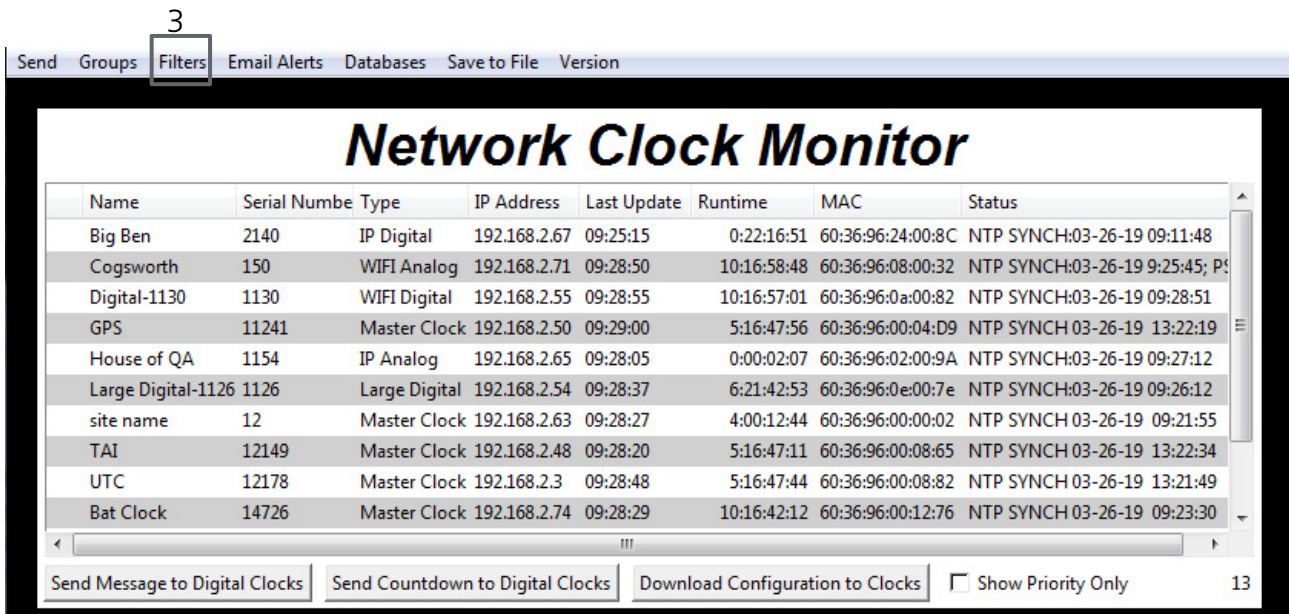

### 3. Filters - When clicked, this button will display the following options:

**Filter By Clock Type** - By selecting this option, the user is able to view specific clock types on the Monitor Screen. The clock types users can filter through are: Master Clocks, Network Repeaters, Wi-Fi Analog, Wi-Fi Digital, IP Analog, and/or IP Digital clocks. When the box next to the clock type is checked, the user will be able to view that clock type on the Monitor Screen.

**Filter By Name** - By selecting this option, the user is able to search for specific clocks by name on the Monitor Screen. The user must type in the name of a clock and check the box next to the word Enable. Once checked, the clocks that match the name will appear.

**Please Note:** When using this option, the submitted name must be identical to the name of the clock in order to receive a match. There are a few special sequences/characters listed below that may be used when filtering by name:

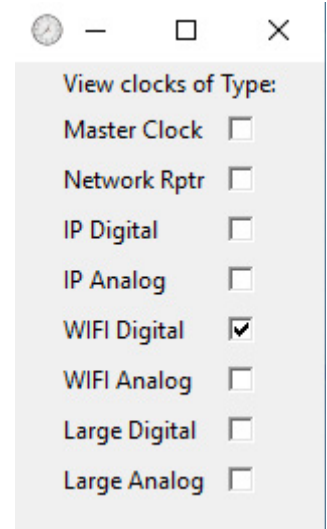

*	Matches any sequence of 0 or more characters in the name
?	Matches any single character in the name
[chars]	Matches any character in the set given by chars. If a sequence of the form x-y appears in chars, then any character between x and y, inclusive, will match.
{[A-Za-z]}	Will match any alphabetical character.
\x	Matches the single character x. This provides a way of avoiding the special interpretation of the characters *?[\] in pattern.

## Network Monitor Software - Task Bar Options

4

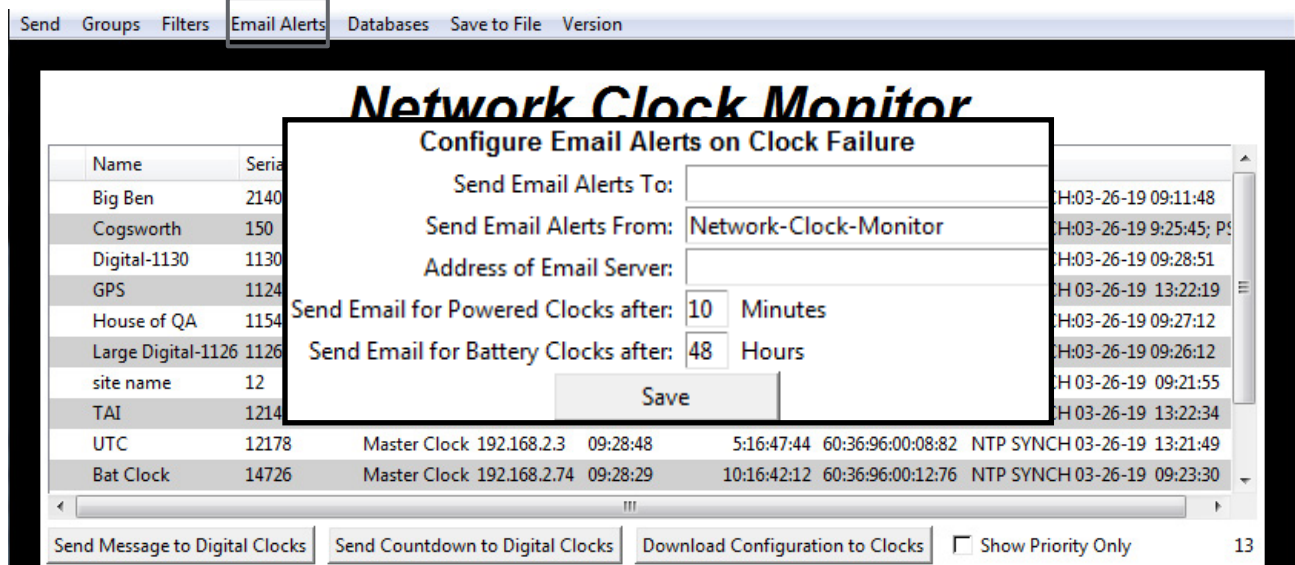

#### 4. Email Alerts - When clicked, this button will display the following options:

**Enable Missing Clock Email Alerts** - By selecting this option, the user will receive an email alert if the Network Monitor Software hasn't heard from a listed clock or other network device after a certain amount of time. This function will not work if the monitor is turned off. Does not apply to battery-powered clocks.

**Enable Low Battery Email Alerts** - By selecting this option, the user will receive an email alert if a battery-powered Wi-Fi Analog clock is synchronizing while low on batteries. This function will not work if the monitor is turned off. Applies only to battery-powered analog clocks. This option is not available with the CFL version of the monitor.

**Configure Email Alerts** - By selecting this option, the user is able to choose which email address the alerts are sent to, the email identity of the sender, the address of the email server, and the amount of time between an event and the email being sent. Once the information is filled in, click the save button. When pressed, this will save all of the settings that were entered.

**Send Test Email** - By selecting this option, the user is able to send a test email to the email address specified in the Configure Email Alerts option.

## Network Monitor Software - Task Bar Options

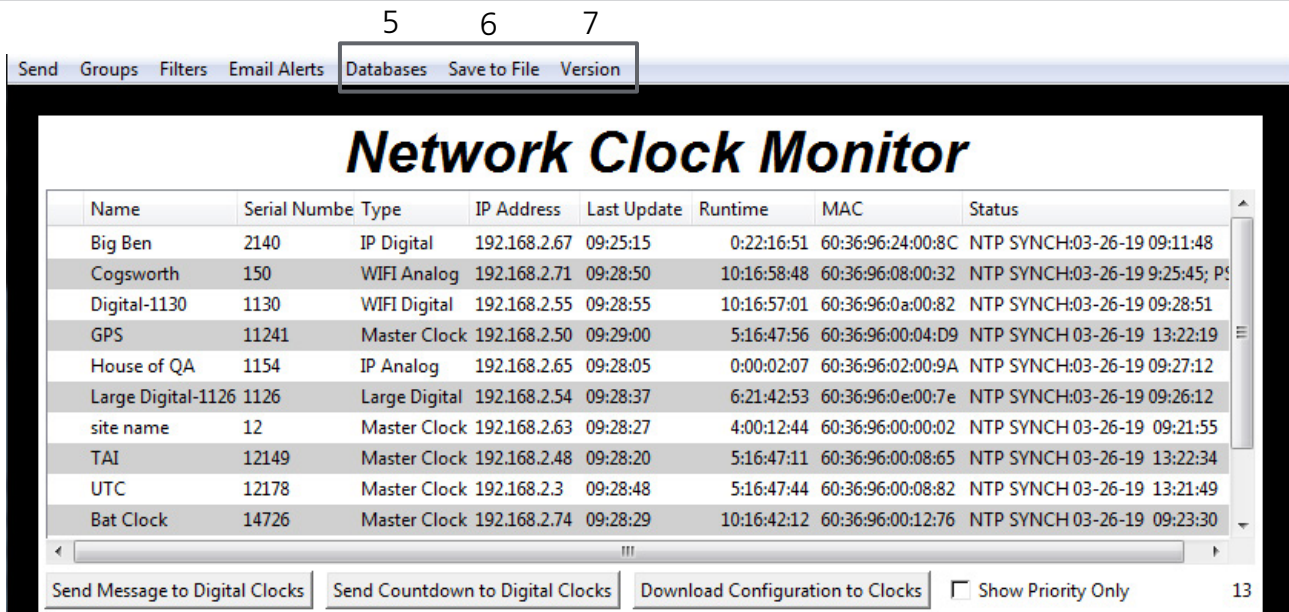

5. **Databases** - When clicked, this button will display the following options:

**Download Configuration** - By selecting this option, the user can load a clock's setting from a PC to another clock of the same type.

**Upload Configuration** - By selecting this option, the user can load the settings from a network clock and save them to a PC.

**Get Wi-Fi Clock Firmware From Server** - Updates software on the selected clock by downloading the latest version from the manufacturer's servers. Applies only to Wi-Fi enabled clocks. This option is not available with the CFL version of the monitor.

**Get Wi-Fi Clock Web Pages From Server** - Updates software on the selected clock's network card and web interface by downloading the latest version from the manufacturer's servers. Applies only to Wi-Fi enabled clocks. This option is not available with the CFL version of the monitor.

6. **Save to File** - When clicked, allows the user to save the all of the information in the Network Monitor device list as a .CSV file, which can be printed from Microsoft Excel. If the monitor is showing devices from a specific Group, then the .CSV file will contain only the devices in that group.

7. **Version** - When clicked, this button will display version number information of the Network Monitor Software and the Software Version Number (SVN). This information is needed only when contacting technical support and will not affect your usage of the Network Monitor Software. This button will also display the Monitor subtype.

**The Network Monitor has two subtypes:**

**CFA** - Intended for use with Wi-Fi Clocks, Master Clocks, Network Repeaters, Wi-Fi Large Digital Clocks, and Network Repeaters.

**CFL** - Intended for use with IP-PoE Digital, Wired IP Large Digital, and IP-PoE Analog Clocks.

## Network Monitor Software - Quick Access Menu

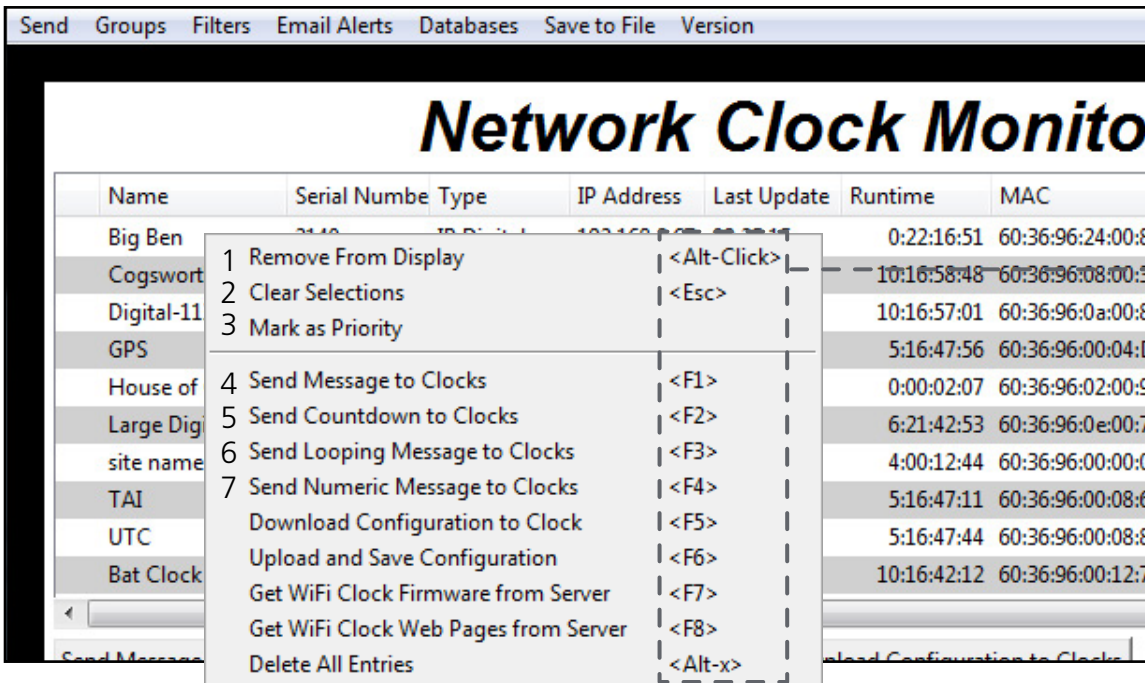

**Please note:** These options can also be accessed by using the keyboard shortcuts noted in the Quick Access Menu

Using a right-handed mouse to right-click on any row in the Device List will open the Quick Access Menu.

- 1. Remove from Display** - When clicked, this option will remove the selected clock from the Device List.
- 2. Clear Selections** - This option will deselect any highlighted items on the Device List.
- 3. Mark as Priority** - Marking a clock(s) as priority is another filtering option for a user to segment the clocks. Once a clock is marked as priority, there will be an asterisk (\*) next to the chosen clock.
- 4. Send Message to Clocks** - Performs the same action as the Send Message to Digital Clocks button.
- 5. Send Countdown to Clocks** - Performs the same action as the Send Countdown to Digital Clocks button.
- 6. Send Looping Message to Clocks** - Performs a similar action to the Send Message to Digital clocks, but allows the user to select the number of times that the message will repeat. It also provides a longer text box for sending longer messages.
- 7. Send Numeric Message to Clocks** - Performs the same action as the Send Message to Digital Clocks button, but messages are limited to four digits consisting of numbers 0-9.



## Network Monitor Software - Quick Access Menu

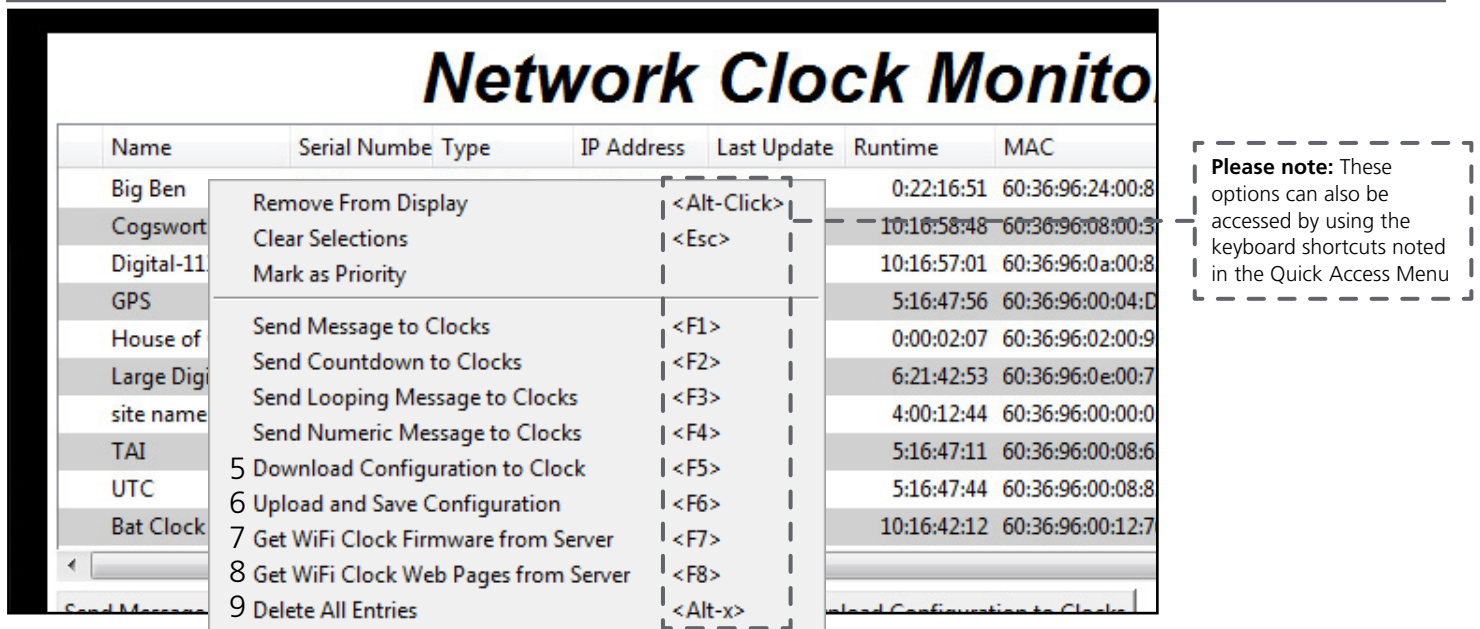

Name	Serial Number	Type	IP Address	Last Update	Runtime	MAC
Big Ben					0:22:16:51	60:36:96:24:00:8
Cogswort					10:16:58:48	60:36:96:08:00:3
Digital-11					10:16:57:01	60:36:96:0a:00:8
GPS					5:16:47:56	60:36:96:00:04:D
House of					0:00:02:07	60:36:96:02:00:9
Large Digi					6:21:42:53	60:36:96:0e:00:7
site name					4:00:12:44	60:36:96:00:00:0
TAI					5:16:47:11	60:36:96:00:08:6
UTC					5:16:47:44	60:36:96:00:08:8
Bat Clock					10:16:42:12	60:36:96:00:12:7

**Please note:** These options can also be accessed by using the keyboard shortcuts noted in the Quick Access Menu

Using a right-handed mouse to right-click on any row in the Device List will open the Quick Access Menu.

**5. Download Configuration to Clock** - If a configuration file was created using "Upload and Save Configuration" on the Quick Access Menu, this option lets the user apply the configuration file to other clocks highlighted within the monitor. This function will not work with Wi-Fi enabled clocks in Direct Mode. Clicking on this item will cause the Download Configuration window to appear:

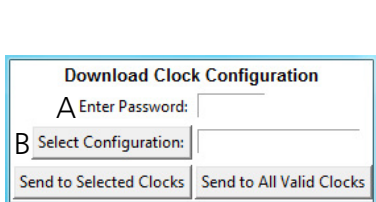

A. Enter Password - The default password is 6063

B. Select Configuration - Pressing the button allows the user to browse their computer for a previously-saved configuration file.

C. Send to Selected Clocks - Applies the configuration file to whichever clocks have been highlighted on the Device List.

D. Send to All Valid Clocks - Applies the configuration file to all applicable devices on the Device List. For instance, a Digital IP clock configuration file would be applied to every Digital IP clock on the Device List.

**6. Upload and Save Configuration** - By selecting this option, the user can copy the settings from an IP device and save them to whichever computer is running the Network Monitor. Your computer will automatically prompt you for the location of the saved configuration file. This function will not work with Wi-Fi enabled clocks in direct mode.

**7. Get Wi-Fi Clock Firmware From Server** - Updates software on the clock by downloading the latest version from the manufacturer's cloud server. Applies only to Wi-Fi enabled clocks. This option is not available with the CFL version of the monitor.

**8. Get Wi-Fi Clock Web Pages From Server** - Updates software on the network card and web interface by downloading the latest version from the manufacturer's cloud server. Applies only to Wi-Fi enabled clocks. This option is not available with the CFL version of the monitor.

**9. Delete All Entries** - Clears all clocks from the Monitor. Clocks will be re-added to the monitor as they check in.

## Network Monitor Software - Error Messages

1. **Characters are Red** - When the characters of a clock have turned red, then the clock has not sent its status within the last 10 minutes.
2. **Characters are Gray** - When the characters of a clock have turned gray, then the clock was once displayed on the Network Monitor, but upon launching the Network Monitor program this most recent time, the clock cannot be found on the network.
3. **Characters are Black** - When the characters of a clock are black, this means that the clock is working normally.

**The CFA and CFL versions of the Monitor cannot run at the same time.** If managing Wi-Fi clocks and IP clocks at the same time, use the CFA Network Monitor instead of the CFL Network Monitor. Be aware, not all features on the CFA Monitor will function on IP-LAN clocks.

You can check if you have the CFA or CFL version by clicking on "Version" at the top of the monitor window.

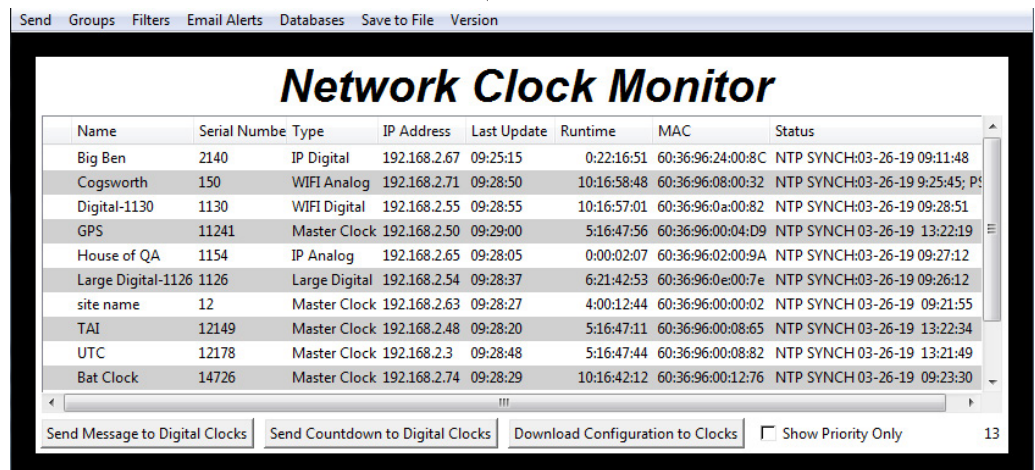



Name	Serial Number	Type	IP Address	Last Update	Runtime	MAC	Status
Big Ben	2140	IP Digital	192.168.2.67	09:25:15	0:22:16:51	60:36:96:24:00:8C	NTP SYNCH:03-26-19 09:11:48
Cogsworth	150	WIFI Analog	192.168.2.71	09:28:50	10:16:58:48	60:36:96:08:00:32	NTP SYNCH:03-26-19 9:25:45; P
Digital-1130	1130	WIFI Digital	192.168.2.55	09:28:55	10:16:57:01	60:36:96:0a:00:82	NTP SYNCH:03-26-19 09:28:51
GPS	11241	Master Clock	192.168.2.50	09:29:00	5:16:47:56	60:36:96:00:04:D9	NTP SYNCH 03-26-19 13:22:19
House of QA	1154	IP Analog	192.168.2.65	09:28:05	0:00:02:07	60:36:96:02:00:9A	NTP SYNCH:03-26-19 09:27:12
Large Digital-1126	1126	Large Digital	192.168.2.54	09:28:37	6:21:42:53	60:36:96:0e:00:7e	NTP SYNCH:03-26-19 09:26:12
site name	12	Master Clock	192.168.2.63	09:28:27	4:00:12:44	60:36:96:00:00:02	NTP SYNCH 03-26-19 09:21:55
TAI	12149	Master Clock	192.168.2.48	09:28:20	5:16:47:11	60:36:96:00:08:65	NTP SYNCH 03-26-19 13:22:34
UTC	12178	Master Clock	192.168.2.3	09:28:48	5:16:47:44	60:36:96:00:08:82	NTP SYNCH 03-26-19 13:21:49
Bat Clock	14726	Master Clock	192.168.2.74	09:28:29	10:16:42:12	60:36:96:00:12:76	NTP SYNCH 03-26-19 09:23:30

---

## Web Interface - Log In

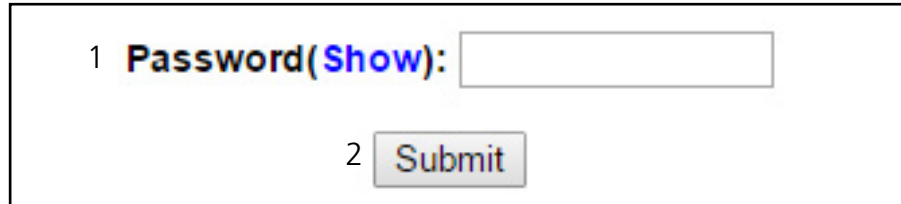
---



1 **Password(Show):**

2 **Submit**

1. **Password** - Location where the password is entered. The default password is **6063**, but this can be changed within the settings.
2. **Submit** - When pressed, the program will check the password. If the password is correct, it will grant the user access to the Web Interface.

## Web Interface - Home Page

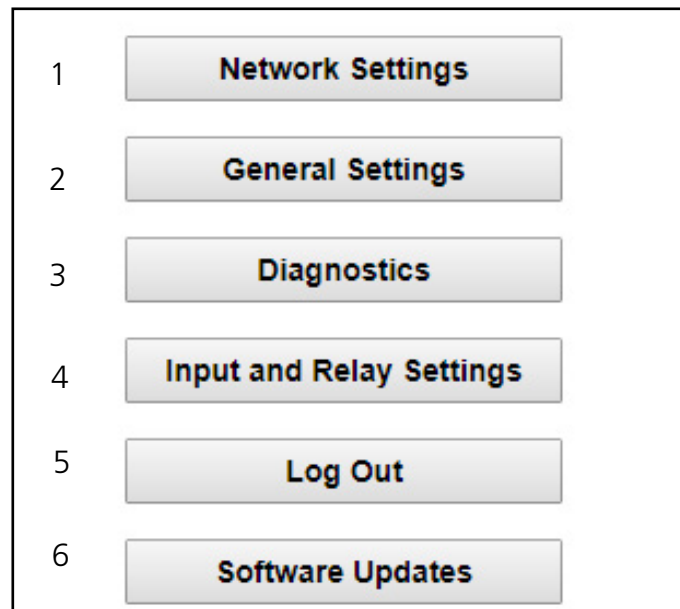

1 **Network Settings**

2 **General Settings**

3 **Diagnostics**

4 **Input and Relay Settings**

5 **Log Out**

6 **Software Updates**

1. **Network Settings** - Takes the user to the Network Settings page. Network Settings includes any setting used by the clock to communicate with the network.
2. **General Settings** - Takes the user to the General Settings page. General Settings includes settings for Time Configuration, Daylight Saving Time, NTP Servers, and Login Settings.
3. **Diagnostics** - Takes the user to the Diagnostics page and troubleshooting options.
4. **Input and Relay Settings** - Takes the user to the Input and Relay Settings page.
5. **Log Out** - Logs the user out of the clock software. The user will need to log back in before they are able to change any settings.
6. **Software Updates** - Takes the user to the Software Updates page.

## Web Interface - Network Settings

### NETWORK SETTINGS

1	Clock Name:	Room 302
2	Serial Number:	1109
3	MAC Address:	60:36:96:0a:00:6d
4	Select Network:	Series1 ▼
5	Network:	Series1
6	Network Password (Show):	
7	DHCP Auto On:	On ▼
8	IP Address:	192.168.4.4
	Subnet Mask:	255.255.255.0
	Gateway Address:	192.168.4.1
	Auto DNS:	On ▼
	DNS Address:	192.168.0.31
	Broadcast to Monitors:	On ▼
	Send Specific Monitor IP:	Off ▼
	Monitor IP Address:	0.0.0.0

[Enterprise Settings](#)

[Submit](#)

1. **Clock Name** - This field allows the user to set a name used to identify the clock on the Network Monitor. This name is also used to identify the clock in a network list while the clock is in Direct-Connect mode. The name must be fewer than 26 characters.
2. **Serial Number** - The clock's serial number. It cannot be changed.
3. **MAC Address** - This field shows the clock's permanent machine address. It cannot be changed.
4. **Select Network** - The clock scans for access points that are broadcasting their network name (SSID), and allows the user to select one instead of manually entering the name in the Network box. You may need to refresh the web page for more network names to appear. **SSIDs must use only English letters, numbers, and spaces. No symbols. SSID is case sensitive.**
5. **Network** - This field allows the user to connect the clock to a wireless network by entering the network name (SSID). The information in this field is overridden if a value was selected in the Select Network field. **SSIDs must use only English letters, numbers, and spaces. No symbols.**
6. **Network Password** - This field allows the user to connect the clock to a wireless network by entering the network password. Network passwords must be 32 characters or fewer. The characters of the password can be shown by placing the computer's cursor over the word "show"**THIS IS ALSO USED AS THE PASSWORD FIELD FOR WPA2-Enterprise NETWORKS.**
7. **DHCP Auto On** - Allows the user to set whether or not the clock will use a DHCP server to determine the IP address, the Gateway IP address, the Subnet Mask, and the DNS Router for the clock.
8. **IP Address** - This field will display the clock's IP address. If DHCP Auto On is enabled, this address will be assigned by the DHCP server. If DHCP Auto On is disabled, then the user must set their own static IP address.

## Web Interface - Network Settings

### NETWORK SETTINGS

	Clock Name:	Room 302
	Serial Number:	1109
	MAC Address:	60:36:96:0a:00:6d
	Select Network:	Series1 ▼
	Network:	Series1
	Network Password (Show):	
	DHCP Auto On:	On ▼
	IP Address:	192.168.4.4
9	Subnet Mask:	255.255.255.0
10	Gateway Address:	192.168.4.1
11	Auto DNS:	On ▼
12	DNS Address:	192.168.0.31
13	Broadcast to Monitors:	On ▼
14	Send Specific Monitor IP:	Off ▼
15	Monitor IP Address:	0.0.0.0
	16	Enterprise Settings
		Submit
	17	

**9. Subnet Mask** - This field allows the user to set the subnet mask for their clock. If DHCP Auto On is enabled, this address will be assigned by the DHCP server. If DHCP Auto On is disabled, then the user must set their own subnet mask.

**10. Gateway Address** - This field allows the user to set the gateway IP address. If DHCP Auto On is enabled, this address will be assigned by the DHCP server. If DHCP Auto On is disabled, then the user must set their own Gateway Address.

**11. Auto DNS** - Allows the user to set whether or not the clock will obtain a Domain Name Server (DNS) address from the network's DHCP server.

**12. DNS Address** - This field allows the user to set the DNS Server IP address. If Auto DNS is enabled, this address will be assigned by the DHCP server. If Auto DNS is disabled, then the user must set their own DNS Address.

**13. Broadcast to Monitors** - Broadcasts the clock's presence to all instances of Network Monitor Software running on the network.

**14. Send Specific Monitor IP** - When set to ON, broadcasts the clock's presence to an instance of the Network Monitor Software running on a specific IP address.

**15. Monitor IP Address** - When Send Specific Monitor IP is set to ON, the clock will broadcast its presence to the IP address entered in this field. If Send Specific Monitor IP is set to off, this field is not accessible.

**16. Enterprise Settings** - Takes the user to a page for WPA2 Enterprise Encryption Settings.

**17. Submit** - Applies any changes to the previous options when pressed. Note that changes to some fields, including IP Address, Subnet Mask, and DNS Address will not be applied until the clock is power-cycled.

---

## Web Interface - Enterprise Encryption Settings

---

### WPA ENTERPRISE SETTINGS

1 **User Name:**

2 **Outer Authentication:**  ▼

3 **Inner Authentication:**

### **THIS SECTION IS REQUIRED ONLY IF YOUR NETWORK USES WPA2-ENTERPRISE ENCRYPTION**

**WPA2-PSK NETWORKS DO NOT REQUIRE USE OF THESE SETTINGS. IF YOUR WI-FI NETWORK PROMPTS YOU FOR A PASSWORD BUT NO USER NAME WHEN CONNECTING, YOU ARE LIKELY USING A WPA2-PSK NETWORK. CONSULT WITH YOUR ORGANIZATION'S NETWORK ADMINISTRATOR FOR QUESTIONS ABOUT YOUR NETWORK SECURITY SETTINGS.**

**1. User Name** - This field allows the user to enter a username for RADIUS Authentication.

**Password** - Is entered on the main network page.

**2. Outer Authentication** - Allows the user to set the outer authentication scheme. The available protocols are EAP-FAST, EAP-TTLS, and EAP-PEAP

**3. Inner Authentication** - Allows the user to see the inner authentication scheme. The only available protocol is EAP-MSCHAP.

**4. Submit** - Applies any changes to the previous options when pressed.

**WPA2-PSK Networks will ignore all settings entered on this page.**

---

## Web Interface - General Settings

---

### GENERAL SETTINGS

- 1 [Time Settings](#)
- 2 [Daylight Saving Time](#)
- 3 [Servers](#)
- 4 [Display Settings](#)
- 5 [Elapsed Timer](#)
- 6 [Login Settings](#)

1. **Time Settings** - Takes the user to the Time Settings page.
2. **Daylight Saving Time** - Takes the user to the Daylight Saving Time page.
3. **Servers** - Takes the user to the Servers page.
4. **Display Settings** - Takes the user to the Display Settings page.
5. **Elapsed Timer** - Takes the user to the Elapsed Timer page. This button will only appear if the Elapsed timer is attached to the clock.
6. **Login Settings** - Takes the user to the Login Settings page.

---

## Web Interface - Time Settings

---

**TIME SETTINGS**

1 **Set Time** 02 ▾ : 08 ▾ PM ▾

2 **Set Date** 09/27/2016

3

4 **GMT Offset** -4

5 **Bias Seconds** 0

6

1. **Set Time** - This setting allows the user to set the clock to a specific time. Fields for each portion of the time may be accessed via the drop-down menu. New NTP data will override this information.
2. **Set Date** - This setting allows the user to set the clock to a specific date. The date must be entered in the following multi-digit format: mm/dd/yyyy where m is a month digit, d is a day of the month digit, y is a digit of the year. New NTP data will override this information.
3. **Change Time** - Applies the information configured in the Set Time and Set Date settings.
4. **GMT Offset** - This setting allows the user to set which time zone the clock will use when displaying the time. For instance, London is an offset of 0, New York is an offset of -5 and Hong Kong is an offset of +8. The clock may be configured to function as part of a Zone Clock through this option.
5. **Bias Seconds** - This setting has two applications:  
**The first application:** is to allow the user to set a fraction of an hour for GMT/UTC offset when the clock is used as a time zone clock and required to present a time where the GMT offset is less than an hour. For example, the city of Adelaide in Australia has a +10:30 GMT/UTC offset. In this scenario, the clock would be configured with +10 hours in field number 9, while for adjusting the half hour difference, the value 1800 seconds should be entered, which reflects 30 minutes.  
**The second application:** Some applications require the clock to display an offset time with a set value from the actual time. For example, if the time received is 12:00, offsetting the bias second + or - will cause the clock to display this offset time from the actual received time. This range permits -9999 seconds to +9999 seconds.
6. **Change Bias/Offset** - Applies the information configured in the GMT Offset and Bias Seconds settings.



## Web Interface - Daylight Saving Time

**DST SETTINGS**

1

**Daylight Saving Time Starts**

Of:  at:

**Daylight Saving Time Ends**

Of:  at:

2

**DST SETTINGS**

1

**Daylight Saving Time Starts**

at:

**Daylight Saving Time Ends**

at:

2

**DST SETTINGS**

1

**North American Group**

US  
Canada (most)  
Baja California  
Bermuda  
Turks and Caicos

2

1. **Method for Defining DST** - There are four methods for defining Daylight Saving Time. The method can be selected from the drop-down menu. Clicking on the Select button displays additional options for that method.

- **Day of the Week in the Month** - This mode allows the user to select the day of the week, month, and time for when the clock will switch to daylight Saving Time. Once the day, month, and time have been set, click Submit to apply the settings to the clock. Example: Second Sunday of March at 2:00.
- **Day of the Month** - This mode allows the user to select the specific day of the month and time for when the clock will switch to daylight saving time. Once the date, month, and time are set, click Submit to apply the settings to the clock. Example: March 1st at 2:00.
- **By Country** - This mode allows the user to select preset Daylight Saving Time information associated with a specific country or group of countries. Select the preset from the drop-down menu, then click Submit to apply the settings to the clock.
- **None** - This mode does not change the clock for Daylight Saving Time.

2. **Submit** - Applies any changes to the previous options when pressed.

## Web Interface - Servers

### SERVER SETTINGS

		<b>Server Performance</b>
1	<b>1st Server Address:</b> <input style="width: 90%;" type="text" value="us.pool.ntp.org"/> <b>2nd Server Address:</b> <input style="width: 90%;" type="text" value="ca.pool.ntp.org"/> <b>3rd Server Address:</b> ● <input style="width: 90%;" type="text" value="de.pool.ntp.org"/> <b>4th Server Address:</b> <input style="width: 90%;" type="text" value="ru.pool.ntp.org"/> <b>5th Server Address:</b> <input style="width: 90%;" type="text" value="uk.pool.ntp.org"/>	EXCELLENT EXCELLENT EXCELLENT EXCELLENT EXCELLENT
	2 <b>Rotate Servers:</b> <input checked="" type="checkbox"/>	<b>Server Performance</b>
	3 <b>Network Sync Every:</b> <input style="width: 80%;" type="text" value="4 Hours"/>	1-20% POOR 20-40% SATISFACTORY 40-60% FAIR 60-80% GOOD 80-100% EXCELLENT
	4 <input type="button" value="Submit"/>	

Sapling Web Server: V.0.0.0

1. **Server Addresses** - These fields allow a user to set the address that the clock will use to obtain NTP time. Web addresses may be entered as a URL or IP address. The active server is identified by the red dot.
2. **Rotate Servers** - When left unchecked, the clock will only attempt to obtain time from the selected NTP server, and will only attempt to try other servers if the selected server fails. When checked, the clock will rotate through the listed addresses each time the clock performs a synchronization check.
3. **Network Sync Every** - Allows the user to decide how often the clock will attempt to acquire NTP time.
4. **Submit** - Applies any changes to the previous options when pressed.

If a Server Address entry is left blank, that entry will be skipped. If all entries are set to blank, the clock will function as an unsynchronized quartz clock. It will leave the network adapter powered down unless it has been activated by a front-panel button-press command.

## Web Interface - Display Settings

### DISPLAY SETTINGS

1 **Time Format:**  ▼

2 **Date Format:**  ▼

3 **Temperature Format:**  ▼

4 **Brightness:**  ▼

5

6 **Time Displayed (seconds):**

7 **Date Displayed (seconds):**

8 **Temp Displayed (seconds):**

9

**1. Display Format** - Allows the user to select how the time is displayed on the clock. There are two options: 12 hour format (3:00AM/3:00PM) or 24 hour format (3:00/15:00).

**2. Date Format** - Sets the date to display in either American style: MM:DD:YY or European style: DD:MM:YY. For 4 digit clocks, the date will display in either American style: MM:DD or European style: DD:MM.

**3. Temperature Format** - If a temperature sensor was installed on the clock, this option allows a user to select whether the temperature appears in Fahrenheit or Celsius.

**4. Brightness** - Sets the brightness level that the clock will display. There are four levels to choose from: High, Medium, Low or Off.

**5. Schedule** - Takes the user to the brightness schedules page.

**6. Seconds Time Displayed\*** - The clock will display the time for the number of seconds entered in the box. After the selected amount of time passes, the clock will change to show Date or Temperature. If a time of 0 is selected, the clock will not display the time. If Date and Temp Displayed are set to 0, the clock will only display the time.

**7. Seconds Date Displayed\*** - The clock will display the date for the number of seconds entered in the box. After the selected amount of time passes, the clock will change to show the Time or Temperature. If a time of 0 is selected, the clock will not display the date. If Time and Temp Displayed are set to 0, the clock will only display the date.

**8. Seconds Temp Displayed\*** - If a temperature sensor was installed on the clock, the clock will display the temperature for the number of seconds entered in the box. After the selected amount of time passes, the clock will change to show the Time or Date. If a time of 0 is selected, the clock will not display the temperature. If Time and Date Displayed are set to 0, the clock will only display the temperature.

**9. Submit** - Applies any changes to the previous options when pressed.

**\*Note:** If the Time, Date, and Temp Displayed are ALL set to 0, the display will turn completely blank. It will turn on for count down/up, and off again once the counting has been cleared.

## Web Interface - Brightness Schedules



### BRIGHTNESS SCHEDULE

<input type="checkbox"/> Sunday	07 : 00	Set Brightness	High	▼	18 : 00	Set Brightness	Low	▼
<input type="checkbox"/> Monday	07 : 00	Set Brightness	High	▼	18 : 00	Set Brightness	Low	▼
<input type="checkbox"/> Tuesday	07 : 00	Set Brightness	High	▼	18 : 00	Set Brightness	Low	▼
<input type="checkbox"/> Wednesday	07 : 00	Set Brightness	High	▼	18 : 00	Set Brightness	Low	▼
<input type="checkbox"/> Thursday	07 : 00	Set Brightness	High	▼	18 : 00	Set Brightness	Low	▼
<input type="checkbox"/> Friday	07 : 00	Set Brightness	High	▼	18 : 00	Set Brightness	Low	▼
<input type="checkbox"/> Saturday	07 : 00	Set Brightness	High	▼	18 : 00	Set Brightness	Low	▼
1	2	<input type="button" value="Submit"/>			4	3		

Web Server: V.1.2.0

- Day Column** - Allows the user to select days where changes to the brightness schedule are active. If a day is not selected, the actions in the adjustment columns will not be applied to the clock.
- Adjustment 1** - Allows the user to select a new brightness level for the clock, and the time when the new brightness level will take effect. Times are entered in 24 hour mode. Brightness options are High, Medium, Low, and Off.
- Adjustment 2** - Allows the user to set a second time during a given day where the brightness level will change.  
  
The time for Adjustment 2 may be set for any time before or after Adjustment 1 during the same day. For example, if Adjustment 1 is set to activate at 11:00 AM and Adjustment 2 is set to activate at 8:00 AM, Adjustment 2 will activate first at 8 AM, followed by Adjustment 1 at 11 AM.  
  
If you wish for the brightness to only change once on a given day, set Adjustment 1 and Adjustment 2 to the same brightness level and time.
- Submit** - Applies any changes to the previous options when pressed.

## Web Interface - Elapsed Timer

### ELAPSED TIMER SETTINGS

	Button Lights	Action	Seconds
1	Lights	Go to CountUp and Start ▼	0
2	Lights	Start/Stop ▼	0
3	Lights	Return to Time Display ▼	0
4	Lights	Go to Countdown and Start ▼	600

### **REFER TO THE ELAPSED TIMER MANUAL FOR ADDITIONAL SETUP INSTRUCTIONS**

A user may set up and configure the Elapsed Timer control panel through this page. For detailed instructions on the many functions and uses of the Elapsed Timer, refer to the Elapsed Timer Manual.

---

## Web Interface - Login Settings

---

### **LOGIN SETTINGS**

1 Viewer Password:

2 Confirm Password:

3 Select User Level  ▼

---

1. **Viewer/Technician/Administrator Password** - Allows the Administrator to set up a new password to the web interface.

2. **Confirm Password** - The new password must also be entered here for a change to be made.

3. **Select User Level** - Allows the Administrator to select an access level for the new password to be applied to. The user levels have the following permissions:

Viewer - Allows the user to view all of the settings in the clock Web Interface, but does not allow the user to add, remove, or change any setting. The default Viewer password is 1111

Technician - Allows the user to view all of the settings in the clock Web Interface and allows the user to change any setting except for those listed on the Login Settings page. The default Technician password is 6063.

Administrator - Allows the user to view and change any setting in the clock Web Interface, including the passwords on the Login Settings page. The default Administrator password is 8085.

4. **Submit** - Applies any changes to the previous options when pressed.

## Web Interface - Diagnostics

### DIAGNOSTICS

1	<b>Software Version:</b> 1.0.1
2	<b>Web Page Version:</b> 1.0.1
3	<b>SVN Revision:</b> 2624
4	<b>Webpage SVN:</b> 2622
5	<b>Run Time From Last Power Up [d h:m:s]:</b> 0 22:19:23
6	<b>Total Run Time [d h:m]:</b> 6 01:02
7	<b>Last Received Signal at [m-d-y h:m:s]:</b> 02-01-17 14:20:12
8	<b>Network Sync Every [m]:</b> 5
9	<b>Worst Server:</b> jp.pool.ntp.org
10	<b>WiFi Signal Strength [dBm]:</b> -37
11	<b>Display [date time status]:</b> 01-31-17 16:05:29 - OK
12	<input type="button" value="Troubleshooting"/>
13	<input type="button" value="Home"/>

1. **Software Version** - Lists the software version for the main processing board of the clock.
2. **Web Page Version** - Lists the software version for the clock's web interface and network card.
3. **Firmware SVN Revision** - Lists the SVN number for the Firmware.
4. **Web Page SVN Revision** - Lists the SVN number for the Web Page.
5. **Run Time From Last Power Up** - Lists the amount of time that has passed since the clock started receiving power.
6. **Total Run Time** - Lists the total amount time that the clock has been powered since it was built.
7. **Last Received Signal at** - Lists the time and date when the clock last received NTP data.
8. **Network Sync Every** - Lists the number of minutes that pass between each time that the clock powers its transmitter to get NTP data.
9. **Worst Server** - Lists the number of the NTP server that has responded the least often when contacted for NTP data. See "Web Interface - Servers" to see the server address/domain associated with each number. When using only 1 server, it will always be shown as the "worst server," as there are no other servers to compare its performance to.
10. **Wi-Fi Signal Strength** - Lists the signal strength between the clock and wireless access point or wireless router in dBm. The closer the number is to 0, the stronger the signal is.
11. **Display [date time status]** - Lists the date and time of the last instance where the display LEDs were tested, and whether or not the test was successful. This time will usually correspond to the last time that the clock was first powered on, or the last time that the Check Display button was pressed on the Troubleshooting page.
12. **Troubleshooting** - Takes the user to the Troubleshooting page. On this page, the user can have the clock check the display for errors, force a time synchronization update, or restore the clock to the factory default settings.
13. **Home** - Returns the user to the "WIFICONFIG" Home Page.

---

## Web Interface - Troubleshooting

---

### TROUBLESHOOTING

- 1
- 2
- 3

1. **Check Display** - When clicked, this button causes the clock to test the LED segments on the clock's display by flashing each one on and off individually in sequence. This will allow the user to determine if one of the segments has failed, so the clock can be sent in for repairs. The clock will return to showing the time after the test is complete.
2. **Force Time Update** - When clicked, this button causes the clock to immediately poll an NTP server and adjust its time accordingly.
3. **Restore Default settings** - When clicked, this button causes the clock to revert to the factory default settings. All data entered by the user will be lost, including network and security parameters. Once the clock has rebooted, it will go into Direct Mode, and will no longer be accessible over the network until new network settings have been entered.



---

## Web Interface - Input and Relay Settings (3300 Only)

---

### INPUT AND RELAY SETTINGS

- 1
- 2
- 3

1. **Inputs** - Takes the user to the Inputs page. This page controls what actions the clock will take when an input is activated.
2. **Outputs** - Takes the user to the Outputs page. This page controls signals outputted by the clock relays.
3. **End Countdown** - Takes the user to the End Countdown page. This page controls the actions that the clock will take whenever a countdown ends.

## Web Interface - Inputs (3300 Only)

### INPUT SETTINGS

Input	Action	Seconds
1	Relay 1 ▼	0
2	Relay 2 ▼	0
3	Relay 1 ▼	0
4	Relay 2 ▼	0

The "Inputs" tab allows a user to program the clock to perform a certain function through a switch or relay contact closure from an outside device such as Code Blue, Nurses Call, etc. Listed below are the options and the function of each one:

**No Action** - This function does nothing if the input is activated.

**Return to Time Display** - Activating the input causes the clock to display the time. If a countdown or count up is in progress, the function is reset when the input is activated.

**Briefly Display Date** - Activating the input causes the clock to briefly display the date. This only works if the clock is displaying the time, not a countdown.

**Go to Count Up and Hold** - Activating the input causes the clock to display and hold at zero.

**Go to Count Up and Start** - Activating the input causes the clock to switch from its current display and begin a count up from zero.

**Go to Count Down and Hold** - Activating the input causes the clock to display and hold at a start time specified by the user in the Seconds box.

**Go to Count Down and Start** - Activating the input causes the clock display to begin counting down from a time specified by the user in the Seconds box.

**Reset** - Activating the input restarts whichever countdown/count up is in progress.

**Start/Stop** - Activating the input causes the timer to pause or resume its counting functions.

**Shift Digits** - Activating the input causes the digits to shift from displaying Hour/Minutes to Minutes/Seconds (Applies to 4 digit clocks only).

**Flash Time** - Activating the input causes the clock to briefly display the time while another function, such as count up or count down, is occurring. Activating the input does not pause, stop, or reset whichever function is occurring at the same time.

**Relay 1/2** - Activating the input causes the listed Output Relay to activate.

**Code Blue /Code Blue 2** - Performs a special-purpose count up. Refer to the section on the next page labeled "Code Blue 1" or "Code Blue 2"

**Function as Elapsed Timer Button 1/2/3/4** - Performs whatever function was programmed for the listed elapsed timer button. This option will only appear if an elapsed timer is connected to the clock.

**Submit** - Applies any changes to the previous options when pressed.

---

## Web Interface - Inputs (3300 Only)

---

Code Blue is a special-purpose count up designed for use in hospitals and other medical facilities. This function overrides the control panel LED settings. The lights are green while the timer is running and red when the timer has been paused.

### **Code Blue 1:**

When an input programmed with Code Blue is activated for the first time, the count up starts.

When the input is activated a second time, the count up pauses. If the input is activated a third time, the count up will resume.

When the input is activated for a period longer than three seconds, the count up resets to zero and the display goes back to showing the time.

If a button programmed with the Start/Stop function is pressed while Code Blue is running, the count up will pause. If Start/Stop is pressed again, the count up will resume.

### **Code Blue 2:**

When an input programmed with Code Blue is activated for the first time, the count up starts.

When the input is activated a second time, the count up pauses. If the input is activated a third time, the count up will resume.

When the input is activated for a period longer than three seconds, the count up resets to zero and the display goes back to showing 00:00:00.

If a button programmed with the Start/Stop function is pressed while Code Blue is running, the count up will pause. If Start/Stop is pressed again, the count up will resume.

---

## Web Interface - Outputs (3300 Only)

---

# OUTPUT SETTINGS

1 **RS485 Data Rate:**  ▼

2 **Relay 1 Output:**  ▼

3 **Relay 2 Output:**  ▼

4

1. **RS485 Data Rate** - Allows the user to decide how often data will be sent by the clock's RS485 port.
2. **Relay 1 Output** - Allows the user to select which time protocol will be sent by the clock through Relay 1. Refer to the next page for output options.
3. **Relay 2 Output** - Allows the user to select which time protocol will be sent by the clock through Relay 2. Refer to the next page for output options.
4. **Submit** - Applies any changes to the previous options when pressed.

## Web Interface - End Countdown (3300 Only)

# COUNTDOWN COMPLETION

### On Countdown Complete:

A Close  for  Seconds

B Go To  Time  CountUp

C Flash Zeros  for  Seconds

D

**A.** When a user schedules a countdown, they may also command a relay to close after a countdown is complete (if using a 3300 Series Digital Clock). This is configured through the configuration window or web interface. Listed below are the options for this function:

- Neither - When the countdown completes, neither relay will close.
- Relay 1 – When the countdown completes, Relay 1 will close for the number of seconds\* entered into the box to the right.
- Relay 2 – When the countdown completes, Relay 2 will close for the number of seconds\* entered into the box to the right.

\* Relays may close for 30 seconds or less. They may not close for more than 30 seconds.

**B.** A user can select what the clock will do after reaching at the end of a countdown by selecting the circle next to either **Time** or **Count Up**. If Time is selected, the clock will display the time at the end of the countdown. If Count Up is selected, then the timer will begin to count up from 0 after the countdown reaches 0.

**C.** If the box next to **Flash Zeros at the end of Countdown** is selected, the digits on the clock will blink on and off once the timer reaches 00:00:00. The zeros will flash for the number of seconds entered into the box to the right.

**D.** Click Submit in order to save and apply the selected options.

### Relay Contact Rating:

- 0.3A at 110 VAC
- 1A at 24 VDC

---

## Web Interface - Software Update

---

<u><b>FIRMWARE UPDATE</b></u>		<u><b>FIRMWARE UPDATE</b></u>	
<b>No Webpage Updates Avail</b>	1	<b>Update Web Pages From Sapling</b>	
<b>Choose File</b> No file chosen	2	<b>Choose File</b> No file chosen	
<b>Update Webpages From File</b>	3	<b>Update Webpages From File</b>	
<b>No Firmware Updates Avail</b>	4	<b>Update Firmware From Sapling</b>	

**\*PLEASE NOTE: If the buttons are grayed out, it means that there are either no updates available or no internet connection.**

1. **Update Web Pages From Sapling** - Updates software on the clock's network card and web interface by downloading the latest version from Sapling's servers.
2. **Choose File** - Allows the user to select a new copy of the network card and web interface software to be uploaded to the Wi-Fi clock. This does not upload the file, it only selects the file.
3. **Update Webpages From File** - Takes whichever file was selected with the Choose File button and applies the update file to the clock.
4. **Update Firmware From Sapling** - Updates software on the clock by downloading the latest version from Sapling's servers.

---

## Manual Controls

---

Some functions of the Wi-Fi Digital Clock can be controlled through the two push-buttons on the face of the clock. That said, it is ALWAYS preferable to use the Web Interface and Network Monitor software when commanding the clock, as these buttons become difficult to access when the clock has been installed on a high wall.

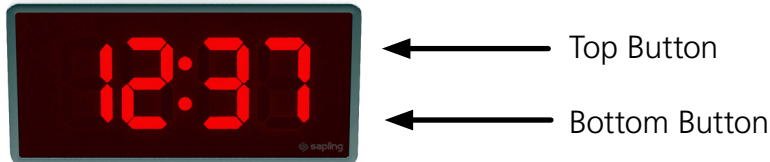

### Display IP Address

When the top and bottom buttons are pressed at the same time, the clock will display the number groups of the IP address. For example, if the IP address of the clock is 192.168.0.80, then the following groups will appear:

[192] [168] [000] [080]

The clock will cycle through the groups twice, then automatically return to displaying the time.

### Simple Count Up

A user can set the clock to simple count-up mode by pressing and releasing the bottom button. When activated, the clock will switch to 00:00:00 (or 00:00 on a 4-digit clock) and the count up will begin immediately.

Pressing the bottom button again will resume count up if the count-up is not running, or pause the count-up if the count up is running.

To exit this mode, quickly press and release the top button and the clock will show the time again.

### Direct Mode

It is possible to connect to the Web Interface without connecting the clock to a network. To enable direct mode, press and release the top button twice. If successful, the message "DIRECT" will appear on the clock display. On a 4-digit clock, only the first four letters will be displayed.

In this mode, the clock's setup 'network' can be accessed the same way that you would any other wireless router or access point. On a Wi-Fi enabled computer, check the available Wireless Networks. Refresh the available networks until a network named Wifi-DIGITAL-#### appears (where #### is the serial number of the clock). This may take up to 30 seconds. Once it appears, connect to this network.

To access the clock in this mode, open a web browser and enter the following web address into the URL field: **192.168.240.1/login.html**

### Reset

The option exists to reset the clock to its factory default settings. Pressing and holding the top and bottom buttons at the same time for more than ten seconds will cause the reset function to activate. The user will know that the reset has been activated, as "RESET" will appear on the clock display. On a 4-digit clock, only the first four letters will be displayed. Once the clock has rebooted, it will go into Direct Mode, and will no longer be accessible over the network until new network settings have been entered.

## Accessing the Clock After it has been Installed

**If the user observes an issue with the clock, please contact your dedicated dealer or us for support.**

The below instructions are provided for accessing the clock for the purpose of changing its settings after it has been installed.

### Surface (wall) Mounted, Dual-Faced, Flag Mounted Clocks:

The clock housing consists of an outer frame (rim) that snaps on to the clock using mounting tabs.

1) To access the clock's electric board, there is a need to gently pull the rim out of the housing as shown in the below image.

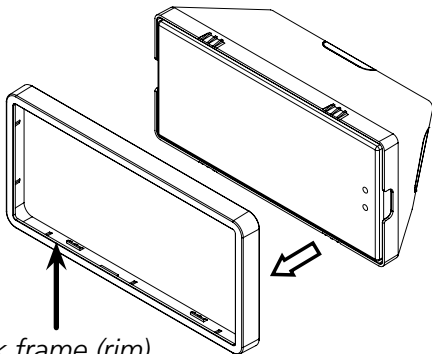

*outer clock frame (rim)*

2) Once the frame (rim) has been removed, gently pull off the clock filter (which is held by four tabs). You may use a flat head screwdriver to pop off the filter by wedging it between the filter and the housing, as shown in the below image.

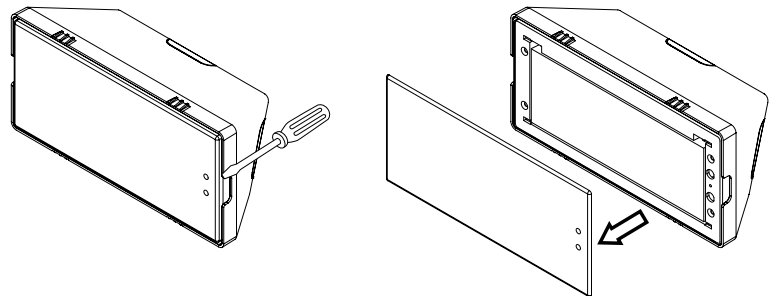

3) Once the filter has been removed, a Phillips screwdriver should be used for unscrewing the clock display from the housing. The clock display is attached to the clock main electrical board, which consists of jumper switches, access to the power and data wires, as well as other ports and interfaces, depending on the clock model (3200 or 3300).

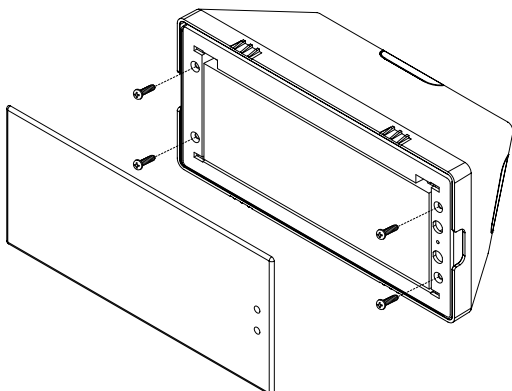

### Placing the clock outer frame (rim) back:

Depending on the clock size, there may be 4 or 6 tabs. Gently push the outer frame (rim) onto the housing, allowing all tabs to latch into position so the rim will evenly align with the clock display.

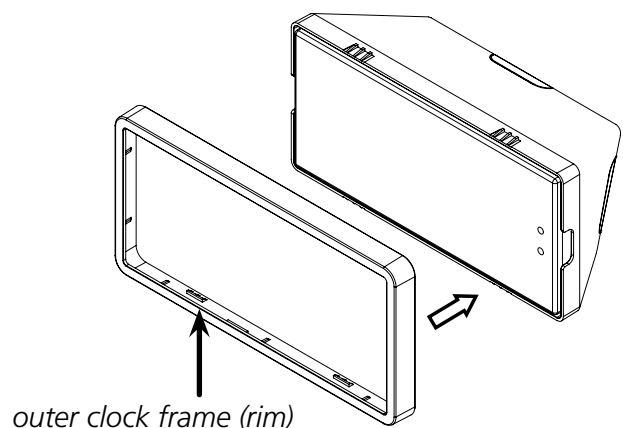

*outer clock frame (rim)*



---

## Frequently Asked Questions

---

### **VERY IMPORTANT:**

CONFIGURE YOUR CLOCK BEFORE MOUNTING IT TO A WALL OR HOUSING. REFER TO THE SYNCHRONIZATION SYSTEM SETUP SECTION OF THIS MANUAL FOR INSTRUCTIONS.

All network equipment must be powered and configured before you install the clock. If the network equipment is not properly installed and powered, and if the clocks have not been configured to communicate with the network equipment, the secondary clocks will not synchronize.

#### **What size utility/gang box is needed?**

A standard double gang box is required for wall mounting all versions of the clock.

#### **Will the wireless clock cause interference with other wireless devices?**

No. The Wi-Fi clock operates a low-power transmitter on the 2.4GHz spectrum, and does not broadcast often enough or powerfully enough to cause interference.

#### **Is the clock compatible with other Wireless Clock systems that use communication protocols other than Wi-Fi?**

No. A Wi-Fi clock obtains data directly from an NTP server through a computer network. It does not and cannot communicate directly with other proprietary clock systems.

#### **How long does it take for a clock to receive correction data?**

On initial power up, if everything is installed and configured correctly, the clock should get NTP data and begin correcting itself within five seconds. The default clock settings will cause the clock to request new NTP data once every five minutes.

If the user wants to manually cause the clock to do this, access the web interface, enter the Diagnostics page, and press the Force Time Update button.

#### **Can I manually set the time on the SBW?**

No. A user should modify settings on the Web Interface to adjust the time displayed on an individual clock. A combination of the GMT Offset and Bias Seconds options can be adjusted to set the clock to the user's preferred time. These options are available through the Time Settings page of the General Settings category.

---

## Troubleshooting

---

### **VERY IMPORTANT:**

CONFIGURE YOUR CLOCK BEFORE MOUNTING IT TO A WALL OR HOUSING. REFER TO THE SYNCHRONIZATION SYSTEM SETUP SECTION OF THIS MANUAL FOR INSTRUCTIONS.

All network equipment must be powered and configured before you install the clock. If the network equipment is not properly installed and powered, and if the clocks have not been configured to communicate with the network equipment, the secondary clocks will not synchronize.

#### **The clock is attached to the power source, but it is not running. What should I do?**

- a. Check to make sure that the wiring in the connector complies with the installation instructions. This information is usually included in step #2.
- b. Make sure that the transformer is an isolated transformer if using a 24 volt model.
- c. Measure the voltage between the power (black) wire and the neutral (white) wire. The voltage between the white and black wires should measure 105-126 volts AC in the 115 volt model, 207-253 volts AC in the 230 volt model, or 21.5-26.5 volts AC/DC in the 24 volt model.

*Failure to follow instructions c and d can result in a blown fuse.*

#### **The clock is not showing the right time. What should I do?**

Enter the web interface and confirm that the GMT Offset, Bias Seconds section, DST Selection have been properly set in accordance with your nation and time zone.

If you have an in-house NTP server, confirm that the NTP server has been set as a time source, and that the server is distributing the correct time.

#### **I am uncertain if my clock is accessing my wireless network. How do I check this?**

If the clock is disconnected from the network, the colon(s) on the clock will blink.

#### **The clock is not receiving data from the NTP server, despite the fact that other nearby clocks are receiving data and properly adjusting. What should I do?**

Enter the clock's Web Interface and confirm that the network and server settings are configured correctly. Ask your network administrator to help you confirm the settings.

If the clock still does not correct, call technical support at (+1) 215.322.6063.

---

## Troubleshooting

---

### **How can it be determined if the clock is receiving a good signal?**

Refer to the Diagnostics page on the Web Interface.

### **The clock is in a location with a poor signal or no signal at all. What do I do?**

You have two options:

1. Boost the transmitter power output of the closest Wireless Router or Wireless Access Point.
2. Install a Wireless Access Point closer to the clock.

### **Why isn't the Wi-Fi clock showing up on my Network Monitor?**

Perform these steps in order until a step causes the clock to appear on the Network Monitor:

1. Wait about two minutes. Some clocks take a few minutes before they appear on the monitor.
2. Confirm that the viewing filters on the Network monitor are set to display Wi-Fi Clocks.
3. Confirm that you have the latest version of the Network Monitor software, as older versions are not able to detect Wi-Fi clocks. Older versions will not have Wi-Fi clocks available as an option on the viewing filter. Your version should be 1.3.1 or newer.
4. Log on to the Clock and, on the Network Settings page, set Broadcast to Monitors to OFF, set Send Specific Monitor IP to ON, enter your computer's IP address into the Monitor IP Address field, then press Submit followed by Log Out. Wait about two minutes for a result.
5. Confirm that the computer or network firewall is not blocking ports 80, 123, or 1777. On Windows machines, the user may receive a prompt the first time that the Network Monitor is used inquiring about network access. Ensure that the monitor software has unrestricted access.
6. Confirm that the computer running the Network Monitor software is on the same subnet as the Wi-Fi clocks. If the clock and computer are on different subnets, one will not see the other. For instance, assuming that a computer has IP address 192.168.1.3, a clock has IP address 192.168.0.4, and both devices have subnet masks of 255.255.255.0, then a Network Monitor on the computer will not be able to see the clock.
7. If the clock has a recorded Static IP, log into the clock's Web Interface and confirm under Network Settings that the clock is broadcasting to all monitors on the network.
8. If all else fails, reconfigure the clock by following the instructions written in the section of this manual named "Synchronization System Setup." Once finished, repeat steps 1 and 2.
9. Confirm that the Wireless Access point is broadcasting using 802.11b, g, or n protocol, and that the SSID does not contain any symbols. The SSID may only consist of letters, numbers, and spaces.
10. Check with your System Administrator to confirm that your security policies permit the clock to be on your network. This includes confirmation of your encryption settings if your clock uses WPA2-Enterprise security protocols.
11. If the clock is still not communicating with the Network Monitor, contact tech support.

---

## Warranty

---

### **Sapling Limited Warranty and Disclaimer**

The Sapling Company, Inc. warrants only that at the time of delivery and for a period of 24 calendar months after delivery or the period stated in this invoice, if different, the Goods shall be free of defects in workmanship and materials, PROVIDED that this warranty shall not apply:

To damage caused by Buyer's or any third party's act, default or misuse of the Goods or by failure to follow any instructions supplied with the Goods.

Where the Goods have been used in connection with or incorporated into equipment or materials the specification of which has not been approved in writing by The Sapling Company, Inc.;

To Goods which are altered, modified or repaired in any place other than a Sapling Company, Inc. factory or by persons not expressly authorized or approved in writing by The Sapling Company, Inc.

THE FOREGOING WARRANTY IS EXCLUSIVE AND IN LIEU OF ALL OTHER WARRANTIES WITH RESPECT TO GOODS DELIVERED UNDER THIS CONTRACT, WHETHER EXPRESS OR IMPLIED, INCLUDING WITHOUT LIMITATION, ANY IMPLIED WARRANTY OF MERCHANTABILITY OR FITNESS FOR A PARTICULAR PURPOSE. The foregoing warranty runs only to Buyer. There are no oral or written promises, representations or warranties collateral to or affecting this contract. Representatives of The Sapling Company, Inc. may have made oral statements about products described in this contract. Such statements do not constitute warranties, shall not be relied on by Buyer and are not part of the contract.

**Note:** An extended 5 year (60 month) warranty is also available at the time of the system purchase with a surcharge.

---

## FCC Statements

---

### **The Federal Communications Commission (FCC) wants you to know:**

This equipment has been tested and found to comply with the limits for a Class B digital device, pursuant to Part 15 of the FCC rules. These limits are designed to provide reasonable protection against harmful interference in a commercial installation. This equipment generates, uses, and can radiate radio frequency energy and, if not installed and used in accordance with the instructions, may cause harmful interference to radio communications. However, there is no guarantee that interference will not occur in a particular installation. If this equipment does cause harmful interference to radio or television reception, which can be determined by turning the equipment off and on, the user is encouraged to try to correct the interference by one or more of the following measures:

- Reorient or relocate the receiving antenna.
- Increase the separation between the equipment and receiver.
- Connect the equipment to an outlet on a circuit different from which the receiver is connected.
- Consult the dealer or an experienced radio/TV technician.

### **FCC Warnings:**

Changes or modifications not expressly approved by the manufacturer could void the user authority to operate the equipment under FCC Rules.

The antenna(s) used for this transmitter must be installed to provide a separation distance of at least 5.78 cm from all persons and must not be co-located or operating in conjunction with any other antenna or transmitter.

FCC ID Number: YOPGS2011MIZ